

Automatic extractor outlet

Type HFA

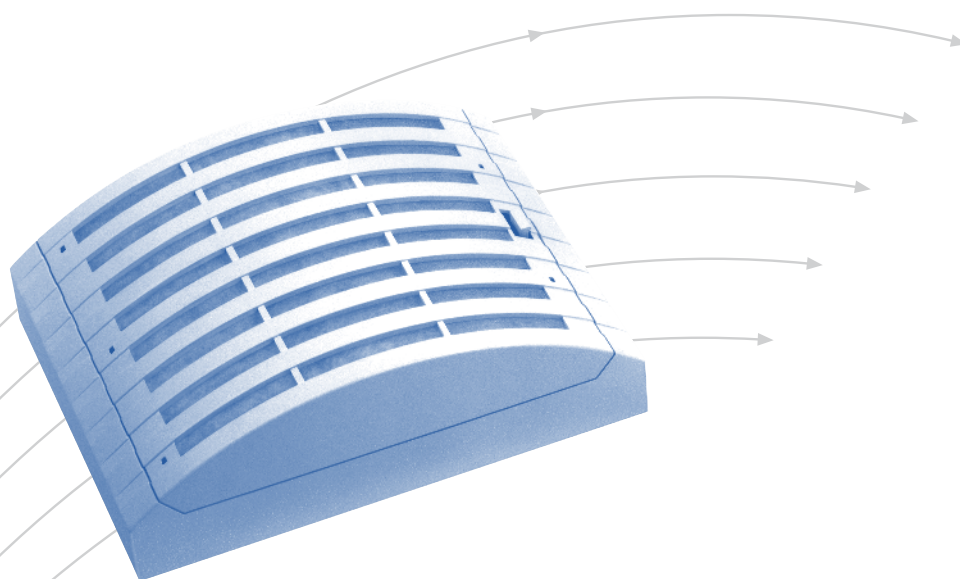

TROX[®] TECHNIK



TROX HESCO Schweiz AG
Walderstrasse 125
Postfach 455
CH - 8630 Rüti ZH

Tel. +41 (0)55 250 71 11
Fax +41 (0)55 250 73 10
www.troxhesco.ch
info@troxhesco.ch

Contents

Application · Realisation · Operation	2
Dimensions	3
Accessories · Installation	4
Technical Data	5-9
Order details	10

Application

The automatic extractor outlet type HFA is designed to provide economy in energy consumption for central extractor systems while at the same time giving a high level of comfort for users.

- Depending on the type of building, heating energy as compared with total consumption can be reduced by 10 - 30%.
- The heating system can be designed to smaller dimensions.
- The HFA extractor outlet is suitable for all buildings with central extractor systems.
- The HFA extractor outlet works with two air volume rates:
 - Base air volume rate \dot{V}_0 (can be selected)
 - Required air volume rate \dot{V} (adjustable)
- When required the damper is automatically opened by an electro-thermal drive with automatic delay (2-3 min.)
- An easily changeable filter pad is incorporated to avoid obstruction of the extractor duct (commercially available filter)
- The HFA automatic extractor outlet is easy to install.

Realisation

The automatic extractor outlet type HFA consists of an attractive removable cover entirely made of recycled plastic material (ABS) in RAL 9003 signal white colour, incorporating a replaceable filter. A base plate in tough plastic material, in RAL 9003 signal white colour. Damper plate with break-out plugs to adjust base air volume rate. Built-in electro-thermal drive with splash-protected connection terminal. The grille is easily removed by gentle pressure on its snap-fastener for replacement or cleaning of the commercially available filter.

Operation of the automatic extractor outlet type

HFA

The HFA extractor outlet operates with two different air volume rates:

Base air volume rate \dot{V}_0

When the ventilated space is not in use, the damper remains closed and only the base air volume rate \dot{V}_0 is evacuated. This base air volume rate can be increased by breaking out one or more plastic plugs in the damper plate.

Required air volume rate \dot{V}

When the ventilated space is in use and the electro-thermal drive is activated by a light switch, the damper opens to the pre-set damper limit A, B, C or D in approx. 2-3 min. The air volume is thus increased to the required rate. By interruption of the contact the damper remains open for approx. 5-10 min. to ensure correct post-ventilation. Then the damper returns to its start position and only the above mentioned base air volume rate is evacuated.

Technical characteristics

Pre-set base air volume rate \dot{V}_0
depending on the negative pressure and
the number of break-out plugs still in place
approx. 7 - 30 m³/h

Adjustable required volume \dot{V}
depending on negative pressure
and damper limits
approx. 30 - 100 m³/h

Negative pressure range
20 - 100 Pa

Nominal voltage
230 V~, 50 Hz

Nominal power rating
8 W

The automatic extractor outlet type HFA can be connected to a duct of Ø100 mm.

Dimensions

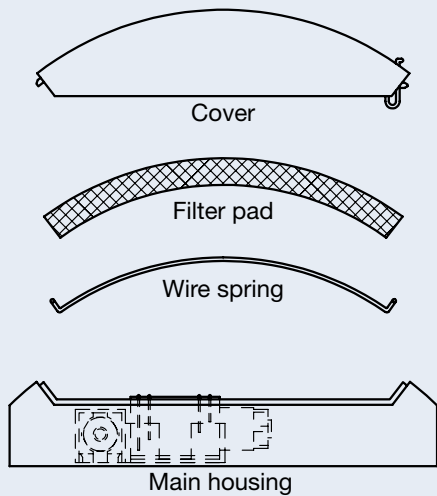

Connection diagram

P = Phase conductor
N = Neutral
E = Earth

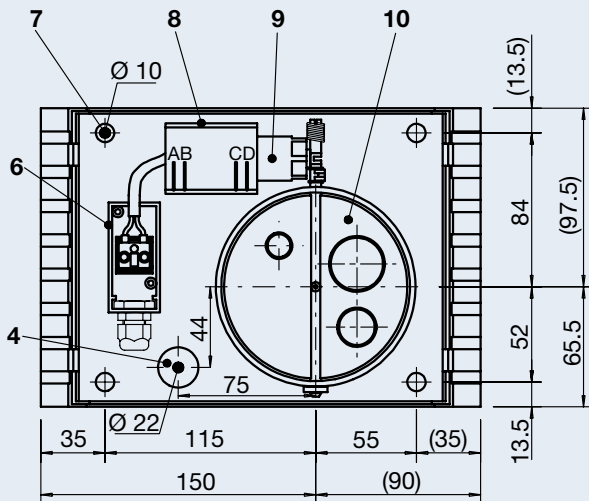
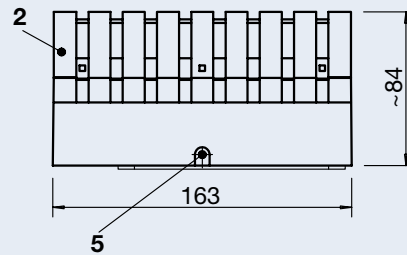
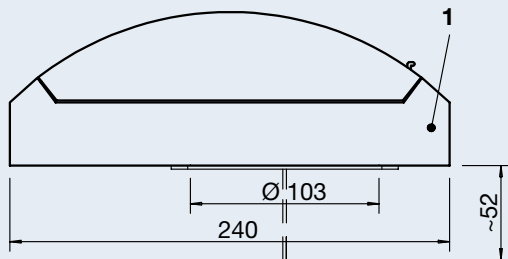
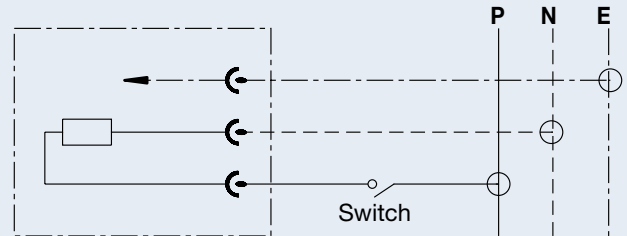

- 1 Main housing
- 2 Cover
- 4 Cable lead-through (under rendering)
- 5 Cable entry (above rendering)
- 6 Electricity box
- 7 Fixing holes
- 8 Junction box
- 9 Electro-thermal drive
- 10 Damper with air volume rate plugs
- 11 EC, SEV approval, specially-insulated equipment with splash-protection

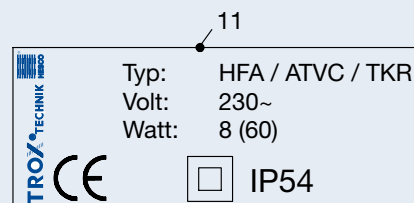

Plug «A» can be removed from the plate «C» after removing the central screw «B». With the central screw «B» removed from the plug «A», the insert «F» can be forced out with a screw-driver at the point marked «D».

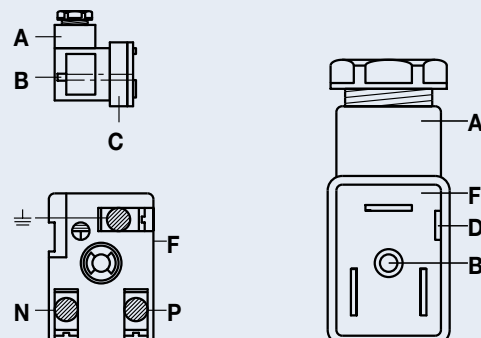

Accessories · Installation

Accessories

The following accessories are supplied with each automatic extractor outlet type HFA:

4 cruciform screws \varnothing 3.5 x 32

4 plastic dowels No. 5 x 25

4 washers \varnothing 4.3 x 14

The foam grommet is glued to the base plate.

Installation

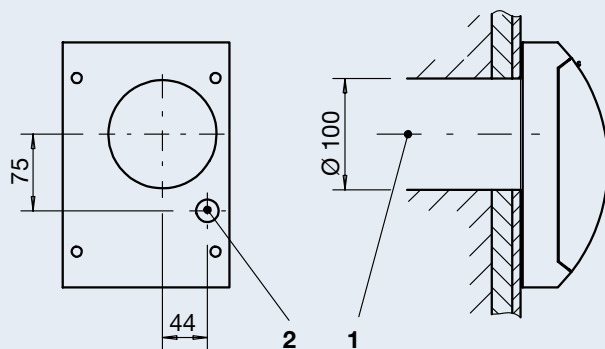

1 Recess for HFA connection in timber-framed wall

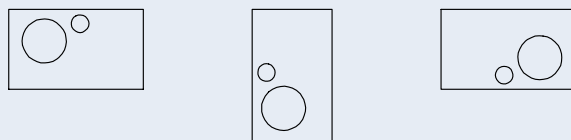

2 The position of the hole for the cable lead-through depends on the installation position of the extractor

1. Determination of the necessary air-flow rate of the ventilator

The necessary air volume rate \dot{V}_{tot} of the ventilator is calculated from the variable air volume rate \dot{V}_{var} of the automatic extractor outlet type HFA and the constant air volume rate \dot{V}_{con} of rooms where the ventilation is not controlled.

1.1 Constant air volume rate \dot{V}_{con}

The constant air volume rate \dot{V}_{con} is made up of the individual air volume rate from rooms with uncontrolled ventilation (without automatic extractor outlets), e.g.

- basements
- drying rooms

1.2 Variable air volume rate \dot{V}_{var}

The variable air volume rate \dot{V}_{var} in the case of a number of automatic extractor outlets consists of the base air volume rate \dot{V}_o (circular gap when rotary shutter is closed) and the required air volume rate \dot{V} (pipe section when rotary shutter is closed), taking a simultaneity factor of 0.5 into account, i.e. in the case of 50% of the automatic extractor outlets installed the rotary shutter is open while 50% are closed. Statistical studies in residential buildings have shown that this simultaneity factor of 0.5 can be counted on as a maximum.

The variable air volume rate \dot{V}_{var} can either be read from the following diagram or calculated from the formula:

$$\dot{V}_{var} = (\dot{V} + \dot{V}_o) \times x \times n$$

- where
- \dot{V}_o = desired base air volume rate
 - \dot{V} = desired demand of air volume rate
 - x = simultaneity factor
 - n = number of automatic extractor outlets

(Formula valid for simultaneity factor of 0.5!)

Example

Given	- N° of automatic extractor outlets	12	
	- Desired demanded air volume rate per automatic extractor outlet	80	m³/h
	- Base air volume rate \dot{V}_o approx.	20	m³/h
Sought	- Constantly ventilated basement	50	m³/h
	- Constantly ventil. drying room	50	m³/h
	- Necessary air volume rate of ventilators \dot{V}_{tot}	m³/h
Solution	$\dot{V}_{var} = (80 + 20) \times 0.5 \times 12 =$	600	m³/h
	$\dot{V}_{con} = 50 + 50 =$	100	m³/h
	$\dot{V}_{tot} =$	700	m³/h

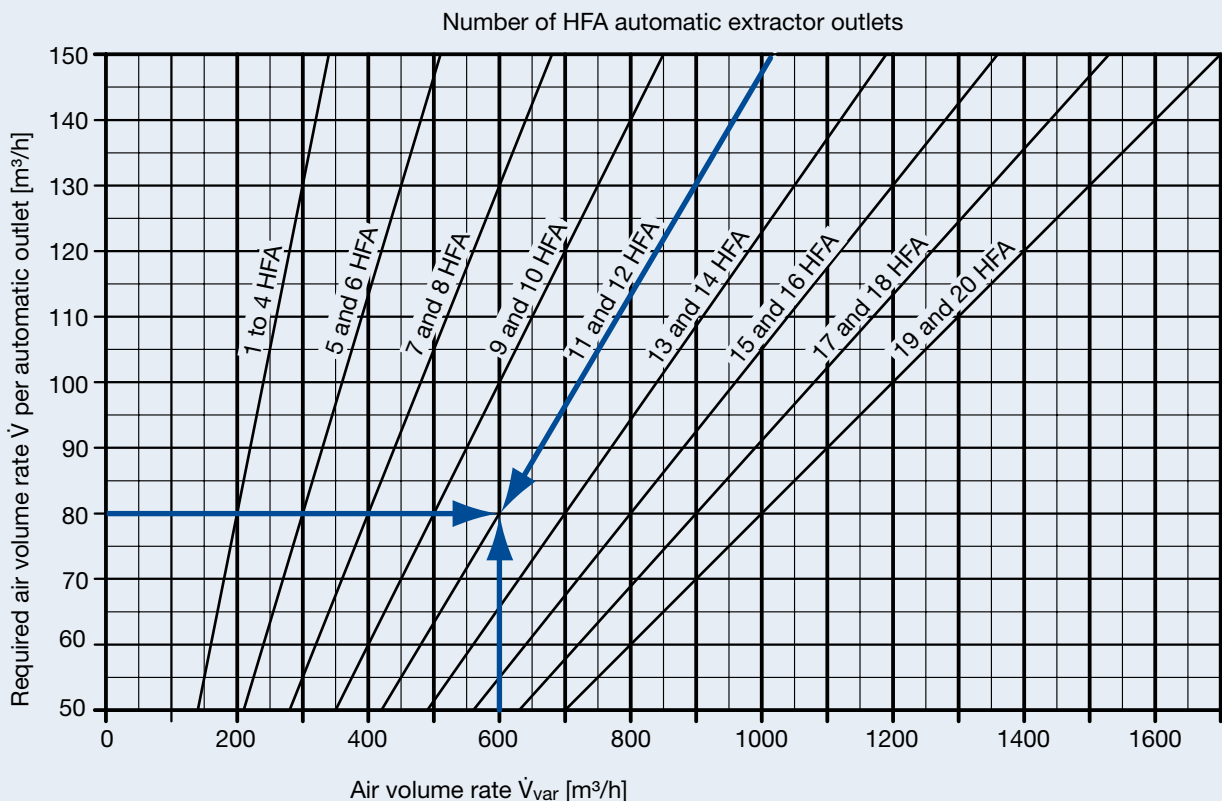

Simultaneity factor = 0.5
 Base air volume rate $\dot{V}_o = 20$ m³/h

Technical Data

2. Determination of the necessary pressure of the ventilator

The necessary pressure to overcome the static resistances in the suction side duct system of the ventilator is calculated as the sum of the individual resistances:

- Pressure loss of the automatic extractor outlet with open rotary shutter
- Pressure loss of the connection and duct
- Pressure loss of the collecting duct

The following diagram can be used for a guide value for the negative pressure. Further resistances such as for instance silencers and dampers must be taken into account by the installer.

Example

Given	- Number of storeys	6
	(2 auto. extractor outlets per storey)	
Sought	- Required negative pressure of ventilator Pa
Solution	- According to diagram	105 Pa

3. Determination of the ventilator (roof ventilator)

The ventilator is determined by the necessary air volume rate and the required negative pressure.

In extractor installations it is important that the ventilator should have the lowest possible characteristic curve if no pressure regulation is included.

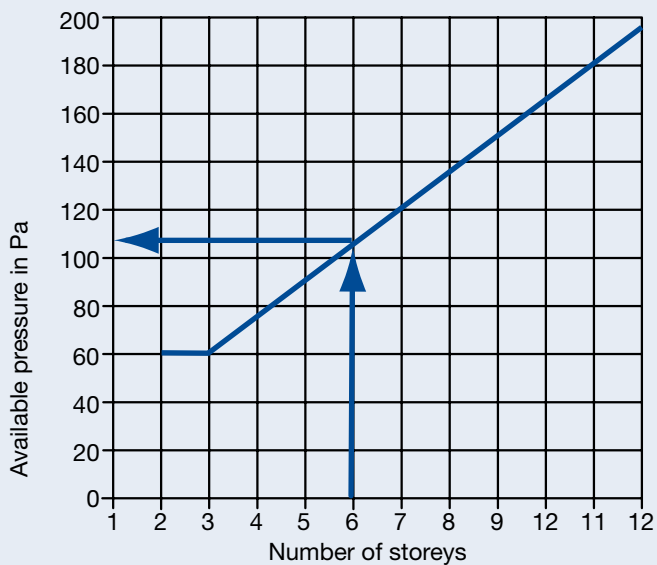

4. Determination of negative pressure for automatic extractor outlets type HFA

In the case of the most unfavourably placed automatic extractor outlets there should still be a negative pressure of about 20 Pa (see diagram on p. 6). To check the pressure loss of the duct system should be calculated, in order to be able to determine the available negative pressure. Presenting of the air-flow rates for the automatic extractor outlets is not possible without determination of the available negative pressure.

The negative pressure actually present can however be measured on the finally fitted installation and the air volume rates set accordingly. For this purpose every automatic extractor outlet type HFA is fitted with a measuring nipple. This method of regulation is more accurate than the calculated determination of the available negative pressure.

Example

Negative pressure created by the ventilator	105 Pa
Pressure loss of the system (calculated)	85 Pa
Available negative pressure at most unfavourably placed automatic extractor outlets type HFA	20 Pa

On the assumption that the pressure loss of the collecting duct takes off around 13 Pa per storey, the following picture emerges:

1st storey Δp_s	= 20 Pa
2nd storey Δp_s	= 33 Pa
3rd storey Δp_s	= 46 Pa
4th storey Δp_s	= 59 Pa
5th storey Δp_s	= 72 Pa
6th storey Δp_s	= 85 Pa

4.1 Examples of installation for extractor conduits

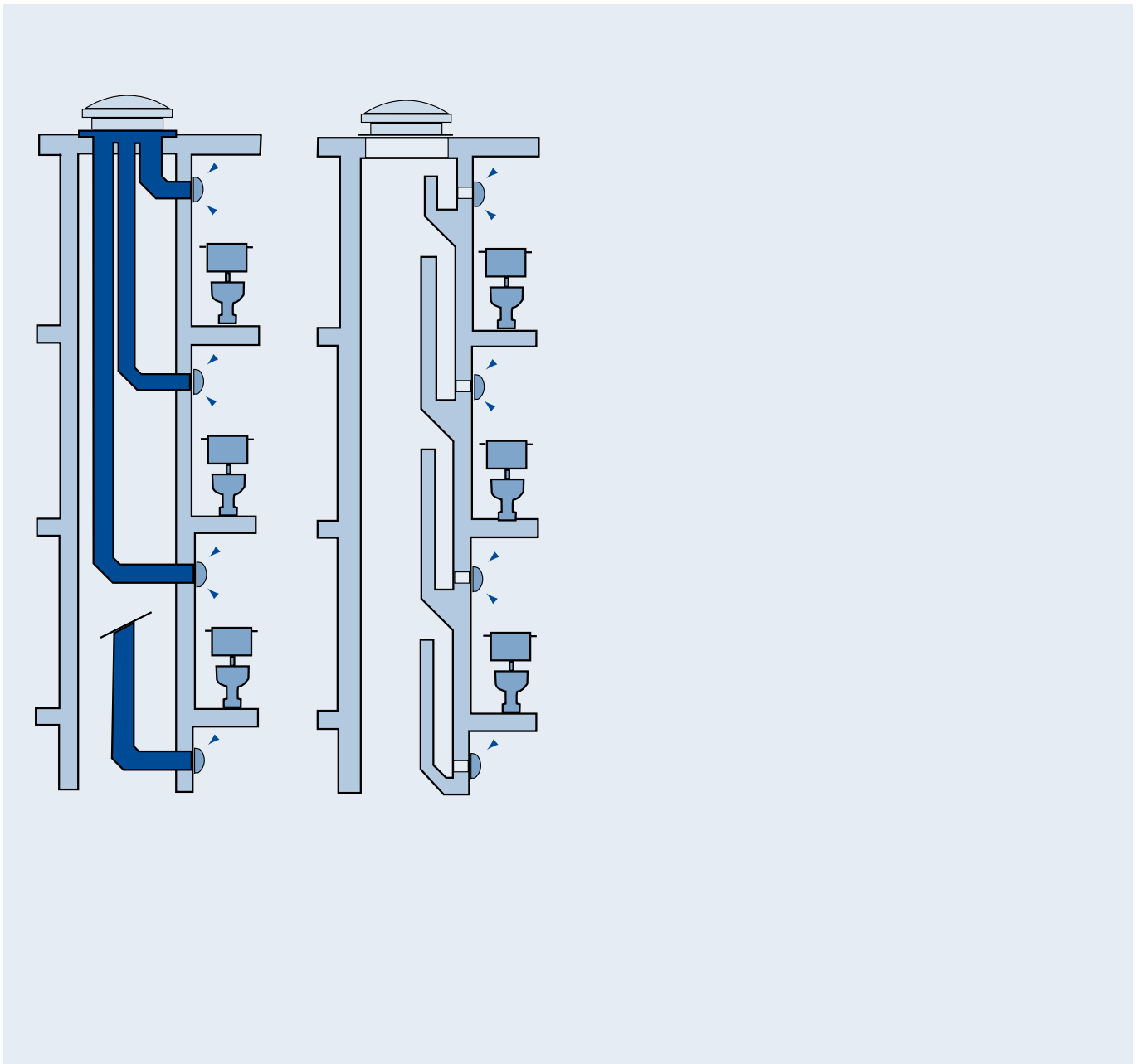

Technical Data

5. Setting air volume rates

5.1 Selection of the base air volume rate \dot{V}_0 of the automatic extractor outlet

The base air volume rate \dot{V}_0 can be increased by removal of the plastic break-out plugs (from setting 0 to setting 1, 2, 3 or 4). This may be necessary in the case of unusually large rooms. In the case of individual bathrooms and WC's the air volume rate \dot{V}_0 is usually not increased, i.e. no plugs are removed (setting 0).

The following example shows the procedure.

Example:

Condition for an air volume rate \dot{V}_0 of 20 m³/h.

Storey N°	Available pressure	Setting	Eff. base air volume rate \dot{V}_0
1	20 Pa	3	21 m ³ /h
2	33 Pa	2	21 m ³ /h
3	46 Pa	1	20 m ³ /h
4	59 Pa	1	22 m ³ /h
5	72 Pa	0	18 m ³ /h
6	85 Pa	0	19 m ³ /h

$$\text{Total } \dot{V}_0 = 122 \times 2 = 244 \text{ m}^3/\text{h}$$

5.2 Adjustment of the required air volume rate \dot{V} of the automatic extractor outlet

The required air volume rate can be limited as desired. Limits A, B, C or D can be selected as shown in the following diagram.

Example

Condition for required air volume rate \dot{V} of 80 m³/h.

Storey N°	Available pressure	Limit	Effective required air volume rate \dot{V}
1	20 Pa	D	72 m ³ /h
2	33 Pa	D	90 m ³ /h
3	46 Pa	C	81 m ³ /h
4	59 Pa	C	92 m ³ /h
5	72 Pa	B	74 m ³ /h
6	85 Pa	B	80 m ³ /h

$$\text{Total } \dot{V} = 489 \times 2 = 978 \text{ m}^3/\text{h}$$

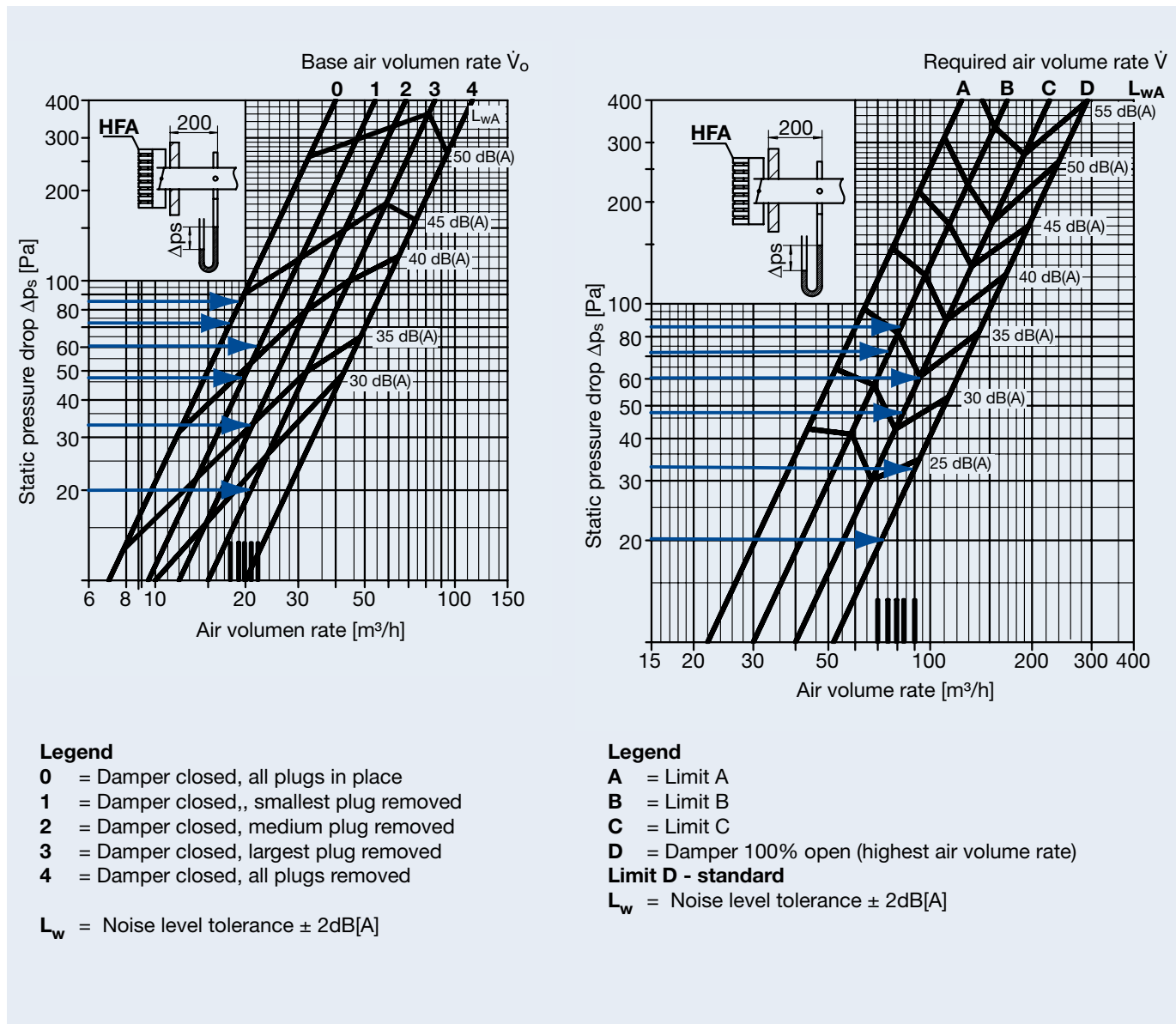

5.3 Control of the effective air volume rate \dot{V}_{tot} with a simultaneity factor of 0.5

Example

- Base air volume rate $\dot{V}_0 = 244 \times 0.5 = 122 \text{ m}^3/\text{h}$
 - Required air volume rate $\dot{V} = 978 \times 0.5 = 489 \text{ m}^3/\text{h}$
 - Constant air volume rate $\dot{V}_{con} = 50 + 50 = 100 \text{ m}^3/\text{h}$
-
- Effective air volume rate \dot{V}_{tot} (assumed air volume rate \dot{V}_{tot}) $711 \text{ m}^3/\text{h}$
 $700 \text{ m}^3/\text{h}$

6. Remarks

It is recommended that a ventilator with the most flat characteristic curve should be selected. This ensures that the available negative pressure does not become unnecessarily high when air volume rate is low.

In large installations it is however advantageous to provide a speed regulation for the ventilator. Automatic speed regulation of rotation can be obtained by means of a constant pressure sensor (pressure transmitter) built in to the network. The position at which pressure is measured depends on the static pressure in the installation. In most cases the pressure sensor is directly mounted in the riser shaft (near the automatic extractor outlets). To obtain optimum regulation a correct calculation of the resistance is necessary.

For smaller installations this type of regulation is much too expensive compared with the gain in terms of economy of electrical energy. Without regulation all that happens is that the base air volume rate \dot{V}_0 is higher than theoretically assumed. A reduction in the required air volume rate \dot{V} obtained by the use of these outlets is well and truly achieved.

7. Acoustic data

7.1 Insertion attenuation from the room into the duct (including connection)

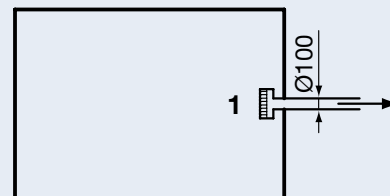

1 HFA Automatic Extractor Outlet

Frequency	Hz	125	250	500	1000	2000	4000	8000
Aut. extractor outlet Shutter closed	dB	27	26	26	29	38	41	47
Aut. extractor outlet Shutter open	dB	21	23	22	27	32	36	41

7.2 Insertion attenuation from the duct into the room (including connection)

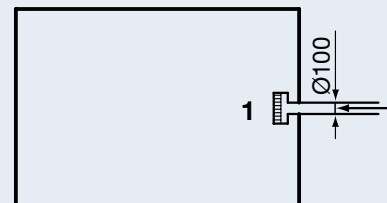

1 HFA Automatic Extractor Outlet

Frequency	Hz	125	250	500	1000	2000	4000	8000
Aut. extractor outlet Shutter closed	dB	22	17	11	9	14	10	17
Aut. extractor outlet Shutter open	dB	22	16	9	5	9	7	6

Order Details

Order codes

No details for standard products

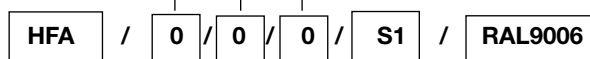

Type ———
Automatic extractor outlet type HFA

RAL 9006 = RAL 9006 matt, 25% brilliance
(all RAL colours possible)

0 = coloured plastic according to RAL 9003 (signal-white)
(standard))

S1 = spray painted according to RAL
(all RAL colours and brilliance on request)

Order examples

36 off HFA
12 off HFA/S1/RAL9006

Text for tendering purposes

Automatic extractor outlet for central, energy-saving
extractor systems with removable cover and dust filter.
The damper is opened by an electro-thermal drive.

Colour RAL 9003 signal white
Including installation accessories