

# Diffusion grilles

Type DG1 / DG3

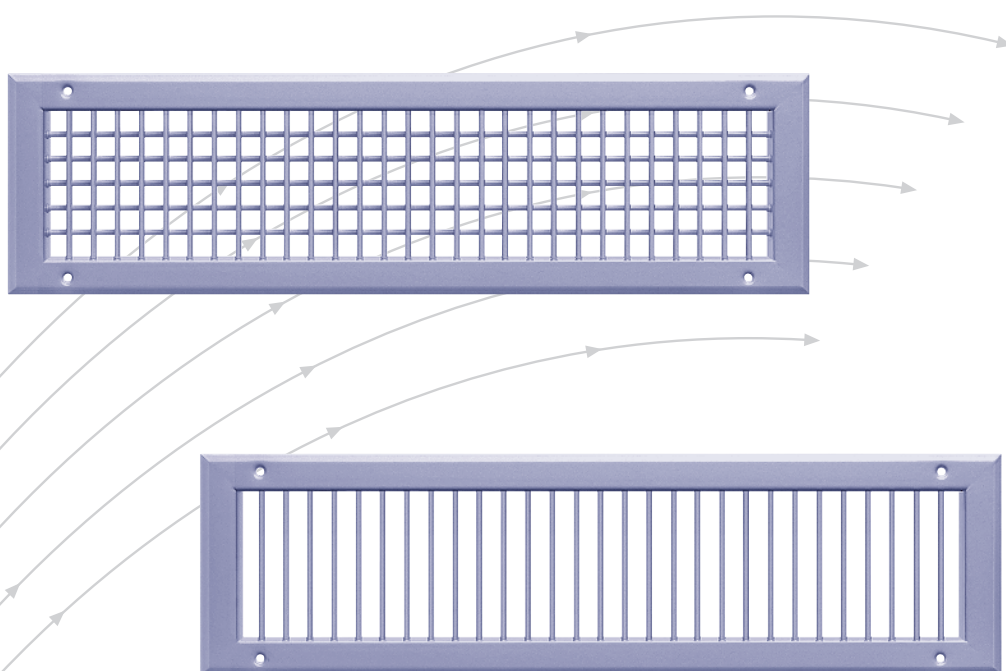

**TROX**® **TECHNIK**



TROX HESCO Schweiz AG  
Walderstrasse 125  
Postfach 455  
CH - 8630 Rüti /ZH

Tel. +41 (0)55 250 71 11  
Fax +41 (0)55 250 73 10  
[www.troxhesco.ch](http://www.troxhesco.ch)  
[info@troxhesco.ch](mailto:info@troxhesco.ch)

# Contents · Applications · Execution · Rapid selection

## Contents

Applications · Execution · Rapid selection	2
Dimensions · Installation	3
Order details	4

## Applications

Type DG1	Diffusion grilles for supply and exhaust air
Type DG3	Diffusion grille for exhaust air

The diffusion grilles do not incorporate any additional dampers. Hence, they are designed mainly for use as individual grille. Only slight pressure differences should be present in a duct which contains several diffusion grilles because greater differences would result in unequal outlet velocities and air volumes. The flow rate can be regulated to some extent for DG1 by bending down the horizontal vanes at the rear and for DG3 by adjusting the blades so that they oppose each other.

## Execution

Folded section angular frame with countersunk mounting holes and glued-on foam gasket.

Blades of drawn tube section. Countersunk mounting holes in the border. Steel, powder coated, color RAL 9010, silky sheen, 60% brilliance.

### Type DG1

Diffusion grille with individually adjustable **vertical and horizontal** blades.

### Type DG3

Diffusion grille with individually adjustable **vertical** blades **only**.

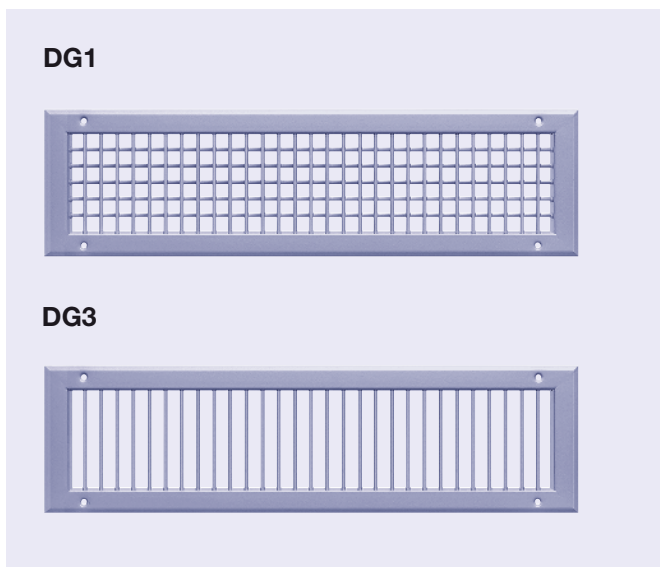

## Rapid selection

Nom. length B [mm]	Nominal height																		
	ZL [m³/h]	H [mm]	AL [m³/h]	ZL [m³/h]	H [mm]	AL [m³/h]	ZL [m³/h]	H [mm]	AL [m³/h]	ZL [m³/h]	H [mm]	AL [m³/h]	ZL [m³/h]	H [mm]	AL [m³/h]	ZL [m³/h]	H [mm]	AL [m³/h]	
200	83	50	97	167	100	195													
250				209	100	243													
300	125	50	146	250	100	292	375	150	438										
400	167	50	195	334	100	390	500	150	585	667	200	780							
500	208	50	243	417	100	487	625	150	730	834	200	974							
600	250	50	292	500	100	584	750	150	876	1000	200	1168	1250	250	1460	1500	300	1752	
750	313	50	365	625	100	730	938	150	1095	1250	200	1460	1563	250	1825				
900				750	100	876	1125	150	1314	1500	200	1752	1875	250	2190	2250	300	2628	

### Base: Directly flowing resp. flowing off

ZL = supply air,  $v_{\text{eff}} = 3.0 \text{ m/s}$ ,  $\Delta p_s = 3.5 \text{ Pa}$

AL = exhaust air,  $v_{\text{eff}} = 3.5 \text{ m/s}$ ,  $\Delta p_s = 8 \text{ Pa}$

$L_w$  for nominal dimension 600 x 100 mm:

$L_{wZL} = 21 \text{ dB(A)}$ ,  $L_{wAL} = 25 \text{ dB(A)}$

### Legend

$v_{\text{eff}}$  = velocity of effective air

$\Delta p_s$  = static pressure drop

$L_w$  = sound power level

# Dimensions · Installation

## Dimensions

Stock assortment

B	D	F	K	O	H	C	J	N
[mm]	[mm]	[mm]	$B + 15^{+2}_0$	$B + 50$	[mm]	$H + 25$	$H + 10^{+2}_0$	$H + 50$
[mm]	[mm]	[mm]	[mm]	[mm]	[mm]	[mm]	[mm]	[mm]
200	167	-	215	250	50	75	60	100
250	217	-	265	300	100	125	110	150
300	267	-	315	350	150	175	160	200
400	367	-	415	450	200	225	210	250
500	467	-	515	550	250	275	260	300
600	567	283.5	615	650	300	325	310	350
750	717	358.5	765	800				
900	867	433.5	915	950				

### DG1 / DG3

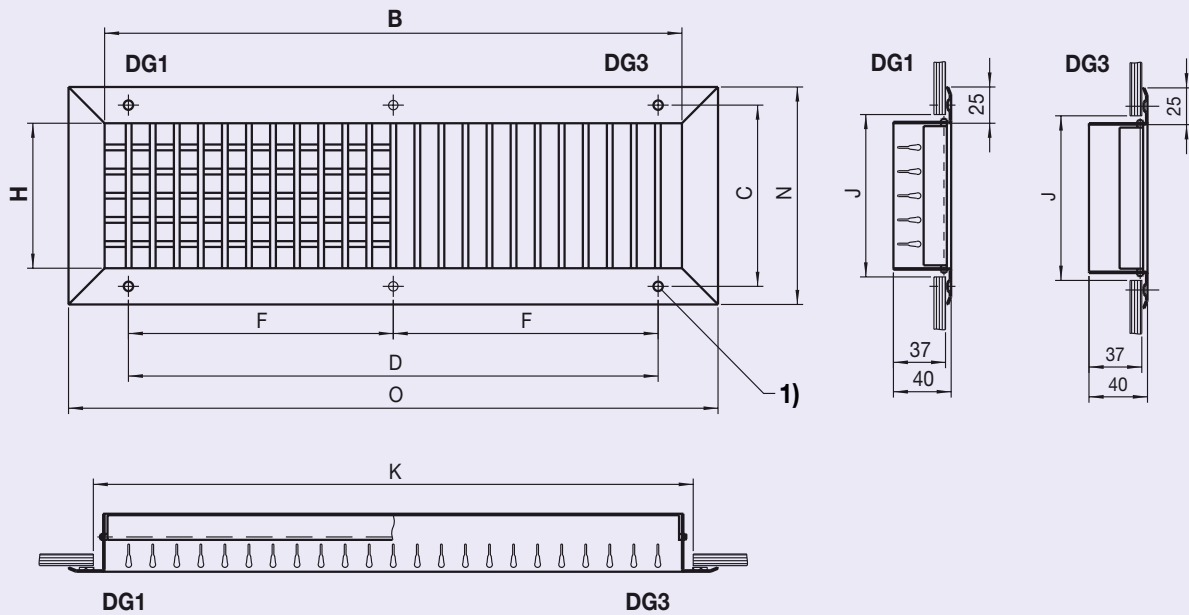

1) Countersunk mounting holes  $\varnothing 4.8 \times 90^\circ$

### Installation

When using sheet metal ducts, the grilles are screwed on directly. For brickwork or plaster ducts we recommend the use of our DG masonry frame.

### Special model

Screwless mounting (designation SL)

### Dimensioning

Outlet velocity, flow rate, throw and pressure drop values are found in 'Dimensioning of TROX HESCO diffusion grilles' L-02-5-01e.

The effective free area in the exhaust plane is 77% of the nominal area  $B \times H$ .

# Order Details

## Order codes

No details for standard products

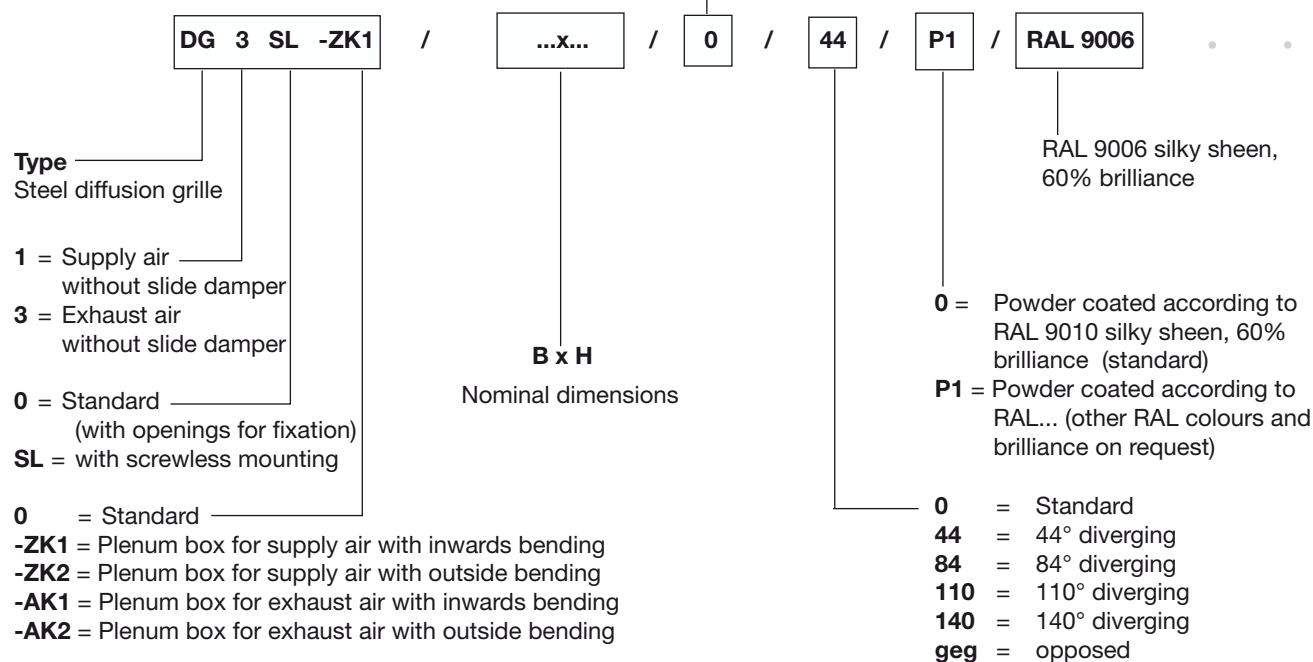

## Order examples

38 off DG1 -ZK1 / 600 x 100  
20 off DG3 SL -AK1 / 900 x 200

## Text for tendering purposes

### Type DG1

Diffusion grille with vertical (in front) and horizontal (behind) blades in streamlined form. Blades space 16.66 mm, dimension of the border 25 mm with gasket of foamed plastics, fastening by screw (sinkholes in the border).

### Material

Grille: Steel powder coated RAL 9010, silky sheen, 60% brilliance.

### Type DG3

Diffusion grille with vertical blades in streamlined form. Blades space 16.66 mm, dimension of the border 25 mm with gasket of foamed plastics, fastening by screw (sinkholes in the border).

### Material

Grille: Steel powder coated RAL 9010, silky sheen, 60% brilliance.