

# Diffusion grille

Type DG5

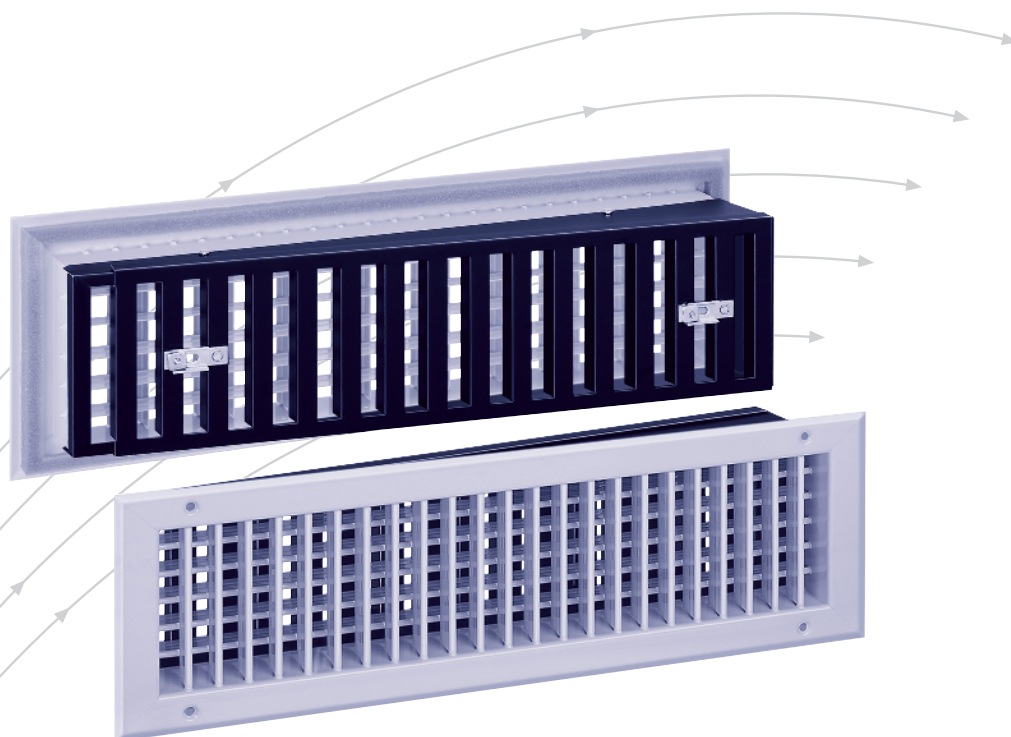

**TROX**® **TECHNIK**



TROX HESCO Schweiz AG  
Walderstrasse 125  
Postfach 455  
CH - 8630 Rüti /ZH

Tel. +41 (0)55 250 71 11  
Fax +41 (0)55 250 73 10  
[www.troxhesco.ch](http://www.troxhesco.ch)  
[info@troxhesco.ch](mailto:info@troxhesco.ch)

## Contents

Application · Realisation _____	2
Dimensions · Rapid selection _____	3
Installation _____	4
Order Details _____	5

Diffusion grille with individually adjustable vertical and horizontal blades (as DG 1). With an additional damper consisting of an inclined flap casing of light metal with tiltable front lid. The deflecting vanes of the flap guarantee constant uniform distribution of air over the entire grille surface.

## Realisation

Grille identical to DG1 (vertical and horizontal blades). Steel, powder coated, color RAL 9010, silky sheen, 60% brilliance. Damper screwed to back side of grille, light metal with front lids and regulating flap as well as deflection vanes. Inner surface stove-enameled in black.

## Special model

D5A flap casing without diffusion grille, with 10 mm bend-off on both long sides (see notes in 'Installation and Layout'), type D5A.

Screwless mounting (designation SL)

## Application

The diffusion grille DG5 is suitable for air supply systems with flow ducts, i.e. with an air velocity in the duct which exceeds the discharge velocity through the grilles.

In order to guarantee uniform air distribution over the grille surface when conventional grilles are used, the pressure chamber principle must be observed, i.e. only structural circumstances often require small duct sections and, consequently, high air velocities. In conventional grilles (such as DG 1, 6) this would result in an unsatisfactory air distribution due to stagnation and turbulence effects as shown in the drawing.

It is advisable in this case to use the diffusion grille DG5.

On one hand, the DG5 provides simple and fast regulation of the system, and on the other hand, it guarantees constant uniform air distribution over the entire grille surface, regardless of the type of flow duct.

The flaps of built-in grilles are adjusted with a Phillips screwdriver as follows:

- Loosen both screws in the flap casing
- Adjust damper flat until the correct air velocity is obtained.
- Retighten the screws

Under certain extreme velocity and pressure conditions, the velocity distribution over the grille surface may not be uniform. This can be controlled by pushing the front lid on the flap casing of the built-in grille into the duct.

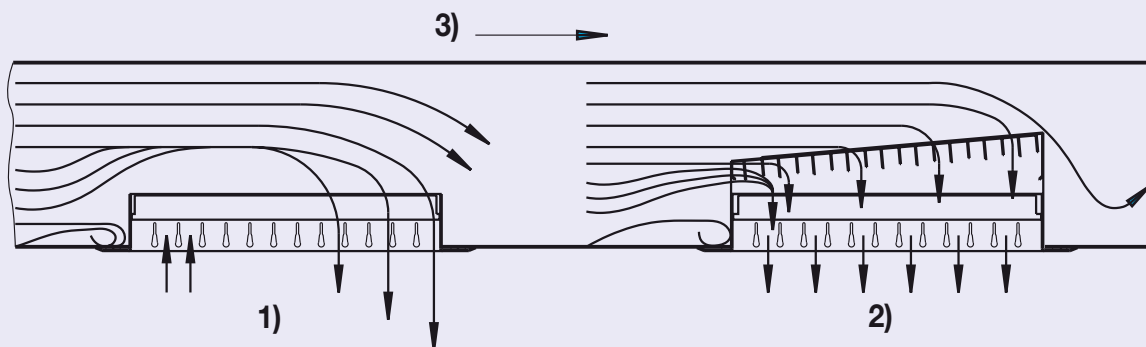

- 1) DG1
- 2) DG5
- 3) Flow direction in the air duct

# Dimensions · Rapid selection

## Dimensions / Rapid selection

Stock assortment

Nom. length B [mm]	Nominal height																
	ZL		H		ZL		H		ZL		H		ZL		H		
	[m <sup>3</sup> /h]	[mm]	[m <sup>3</sup> /h]	[mm]	[m <sup>3</sup> /h]	[mm]	[m <sup>3</sup> /h]	[mm]	[m <sup>3</sup> /h]	[mm]	[m <sup>3</sup> /h]	[mm]	[m <sup>3</sup> /h]	[mm]	[m <sup>3</sup> /h]	[mm]	
200	83	50	167	100													
250			209	100													
300	125	50	250	100	375	150											
400	167	50	334	100	500	150	667	200									
500	208	50	417	100	625	150	834	200									
600	250	50	500	100	750	150	1000	200	1250	250							
750	313	50	625	100	938	150	1250	200	1563	250							
900			750	100	1125	150	1500	200	1875	250							

### Base: Directly flowing resp. flowing off

ZL = supply air,  $v_{\text{eff}} = 3.0 \text{ m/s}$ ,  $\Delta p_s = 3.5 \text{ Pa}$

$L_w$  for nominal dimension 600 x 100 mm:

$L_{wZL} = 21 \text{ dB(A)}$

### Legend

$v_{\text{eff}}$  = velocity of effective air

$\Delta p_s$  = static pressure drop

$L_w$  = sound power level

B	D	F	K	O	T	H	C	J	N
[mm]	[mm]	[mm]	$B + 15 \cdot \frac{2}{0}$	$B + 50$	[mm]	[mm]	$H + 25$	$H + 10 \cdot \frac{2}{0}$	$H + 50$
[mm]	[mm]	[mm]	[mm]	[mm]	[mm]	[mm]	[mm]	[mm]	[mm]
200	167	-	215	250	75	50	75	60	100
250	217	-	265	300	80	100	125	110	150
300	267	-	315	350	85	150	175	160	200
400	367	-	415	450	95	200	225	210	250
500	467	-	515	550	100	250	275	260	300
600	567	283.5	615	650	110				
750	717	358.5	765	800	130				
900	867	433.5	915	950	150				

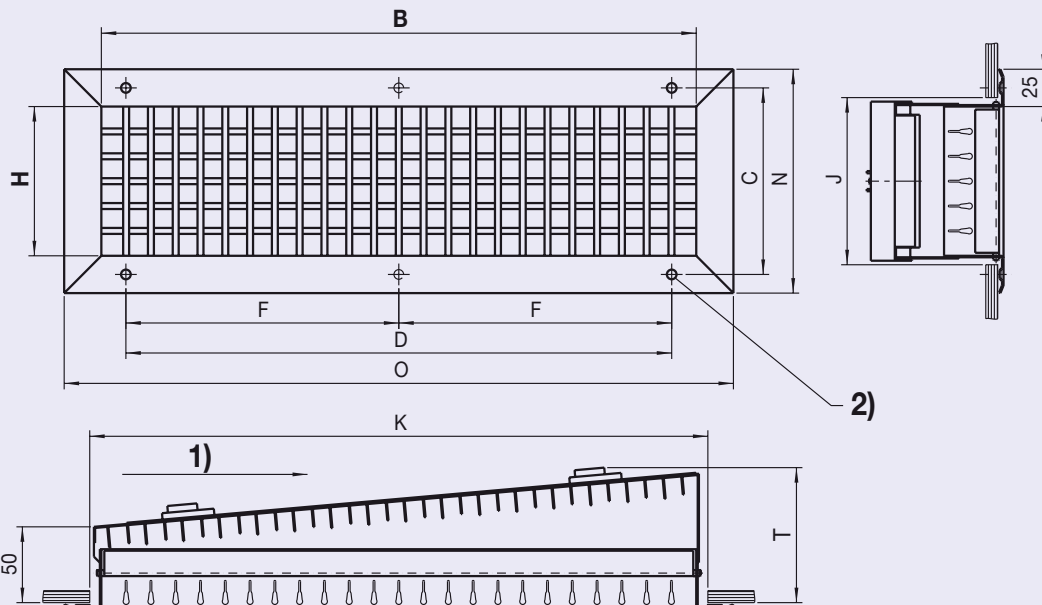

1) Air direction in the duct

2) Countersunk mounting holes  $\varnothing 4.8 \times 90^\circ$

# Installation

## Dimensioning

Exhaust velocity, flow rate, pressure drop, and throw values are found in 'Dimensioning of TROX HESCO diffusion grilles' L-02-5-01e.

We also recommend:

### for air-conditioning systems

exhaust velocity 2-3 m/sec

air velocity in duct up to 6 m/sec

### for industrial systems

exhaust velocity depending on throw

air velocity in duct up to 15 m/sec

The effective free area in the exhaust plane is 77% of the nominal area  $B \times H$  except on the flap, where it is only 43%.

## Installation and Layout

Screwed directly onto the supply duct or, in case of brickwork, on the standard DG masonry frame.

It should be noted that the full effect of the DG5 is only achieved if the flap casing protrudes into the air duct. If the supply duct is mounted outside the rooms, as is often the case, the air must be conducted to the supply grilles through wall penetrations by means of feed pipes.

For this case we recommend our DG1 and DG5 flap casings without grilles with 10 mm bend-off on both long sides. This will permit the correct installation of the flap casing into the supply duct, as shown in the drawing below. Thus, a faultless assembly which includes all advantages of the DG5 can also be obtained in this case.

These flap casings alone are also suitable as distributing and regulating elements for distribution ducts in perforated ceilings.

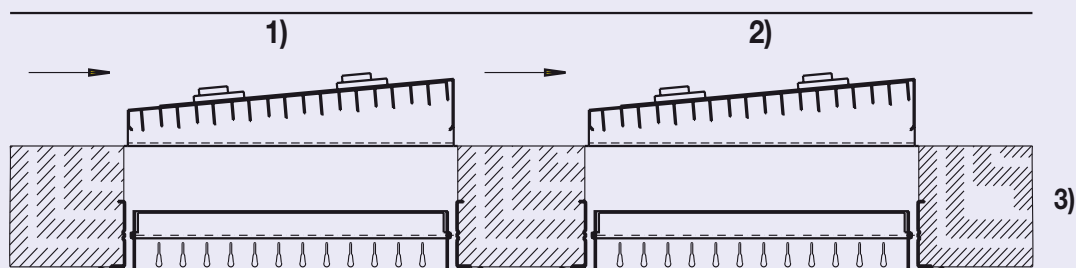

- 1) Air duct
- 2) D5A-flap casing
- 3) Wall

## Order codes

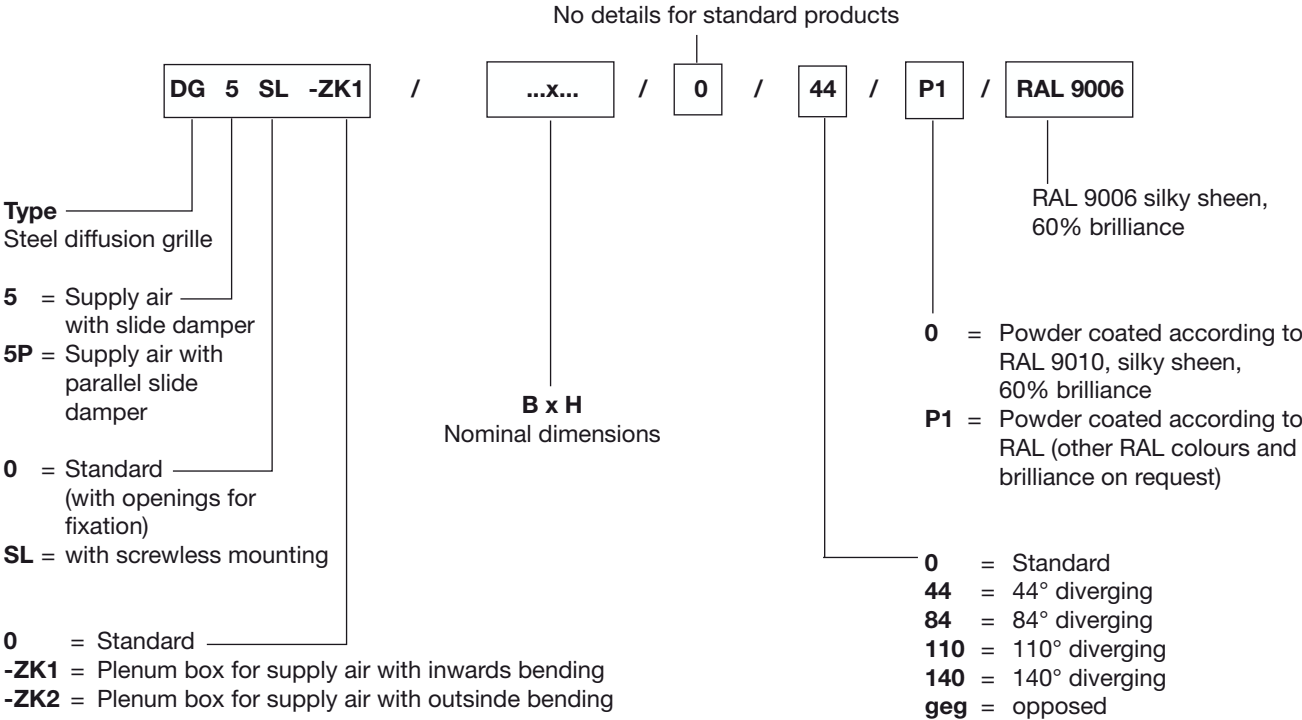

## Order examples

20 off DG5 -ZK2 / 600 x 100 / 44 / P1 / RAL9006  
 30 off DG5 SL -ZK1 / 900 x 200

## Text for tendering purposes

Diffusion grille with vertical (in front) and horizontal (behind) blades in streamlined form. Blades space 16.66 mm, dimension of the border 25 mm with gasket of foamed plastics, fastening by screw (sinkholes in the border). With an additional damper consisting of an inclined flap casing of light metal with tiltable front lid. The deflecting vanes of the flap guarantee constant uniform distribution of air over the entire grille surface.

## Material

Grille: Steel, powder coated RAL 9010, silky sheen, 60% brilliance.

Damper: screwed to back side of grille, light metal with front lids and regulating flap as well as deflection vanes. Inner surface stove-enameled in black.

