

Diffusion grilles

Type DG7 / DG17

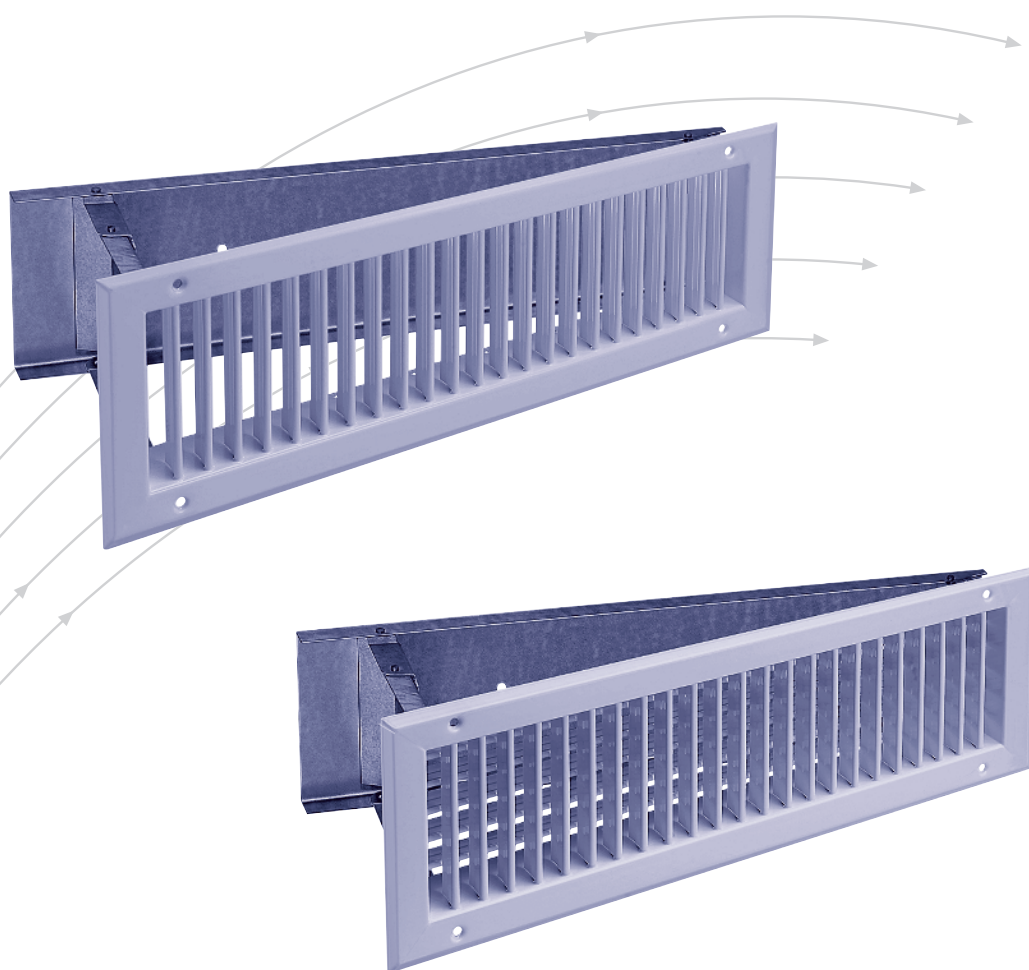

TROX® **TECHNIK**



TROX HESCO Schweiz AG
Walderstrasse 125
Postfach 455
CH - 8630 Rüti /ZH

Tel. +41 (0)55 250 71 11
Fax +41 (0)55 250 73 10
www.troxhesco.ch
info@troxhesco.ch

Contents

Application · Realisation · Rapid selection	2
Dimensions · Installation	3
Order Details	4

Application

Type DG7 Exhaust air grille

Type DG17 Supply air grille

Air supply grille specially designed for industrial systems with high-velocity ducts. In combination with the baffle plate, the tilt-down closure panel provides good flow-rate control and uniform air distribution to both grille halves. For air-conditioning systems, we recommend the DG 5 since it provides better air control and direction.

Realisation

Folded section angular frame with countersunk mounting holes and glued-on foam gasket. Deflector with baffle plate for flow-rate control mounted on back side.

Grille: steel powder coated, color RAL 9010, silky sheen, 60% brilliance.

Deflector: sendzimir-galvanized steel

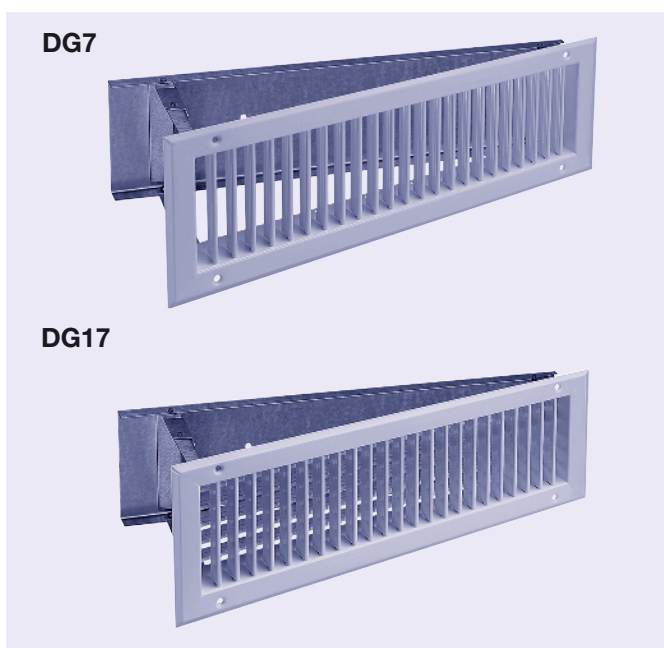

Type DG7

Grille as DG3 with individually adjustable **vertical** blades only.

Type DG17

Grille as DG1 with individually adjustable **vertical** and **horizontal** blades.

Dimensions / Rapid selection

The diffusion grilles DG7 and DG17 are available only in the sizes listed below.

Stock assortment

Nom. length B [mm]	Nominal height												C [mm]	D [mm]	
	ZL [m³/h]	H [mm]	AL [m³/h]	ZL [m³/h]	H [mm]	AL [m³/h]	ZL [m³/h]	H [mm]	AL [m³/h]	ZL [m³/h]	H [mm]	AL [m³/h]			
200	83	50	97	167	100	195							167	-	
250				209	100	243							217	-	
300	125	50	146	250	100	292	375	150	438				267	-	
400	167	50	195	334	100	390	500	150	585	667	200	780	367	-	
500	208	50	243	417	100	487	625	150	730	834	200	974	467	-	
600	250	50	292	500	100	584	750	150	876	1000	200	1168	1250	250	1460
750	313	50	365	625	100	730	938	150	1095	1250	200	1460	1563	250	1825
900				750	100	876	1125	150	1314	1500	200	1752	1875	250	2190

Dimensions · Installation

Base: Directly flowing resp. flowing off

ZL = supply air, $v_{\text{eff}} = 3.0 \text{ m/s}$, $\Delta p_s = 3.5 \text{ Pa}$

AL = exhaust air, $v_{\text{eff}} = 3.5 \text{ m/s}$, $\Delta p_s = 8 \text{ Pa}$

L_w for nominal dimension 600 x 100 mm:

$L_{wZL} = 21 \text{ dB(A)}$, $L_{wAL} = 25 \text{ dB(A)}$

Legend

v_{eff} = velocity of effective air

Δp_s = static pressure drop

L_w = sound power level

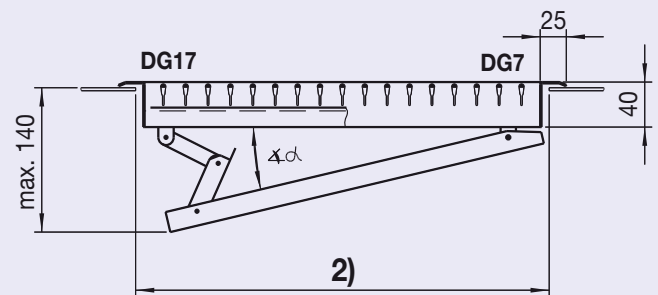
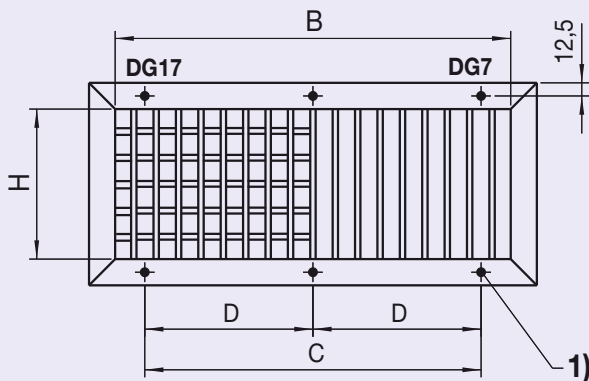

1) Countersunk mounting holes $\varnothing 4.8 \times 90^\circ$

2) Opening in sheet metal duct $B + 15^{+2}_0 \text{ mm}$, $H + 10^{+2}_0 \text{ mm}$

Supply air

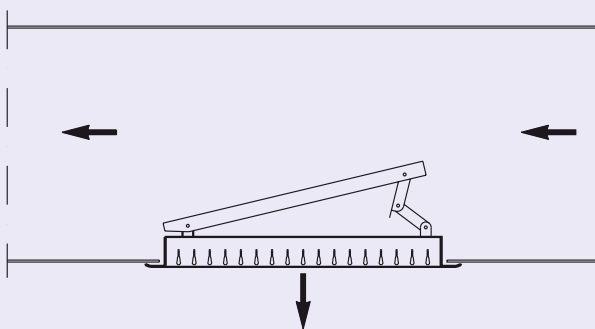

Exhaust air

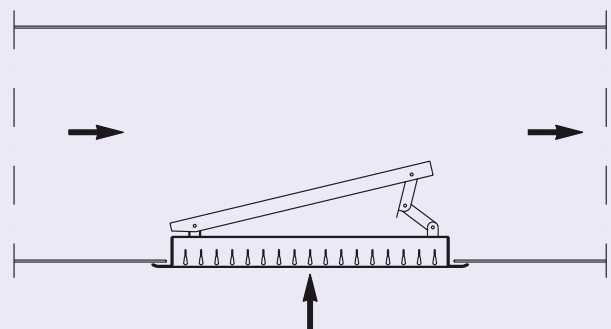

Installation

When using sheet metal ducts, the grilles are screwed on directly. For brickwork or plaster ducts we recommend the use of our DG mansory frame.

Special model

Screwless mounting (designation SL)

Dimensioning

Air velocity, flow rate, and pressure drop values are found in 'Dimensioning of TROX HESCO diffusion grilles' L-02-5-01e.

The effective free area in the exhaust plane is 77% of the nominal area $B \times H$.

Order Details

Order codes

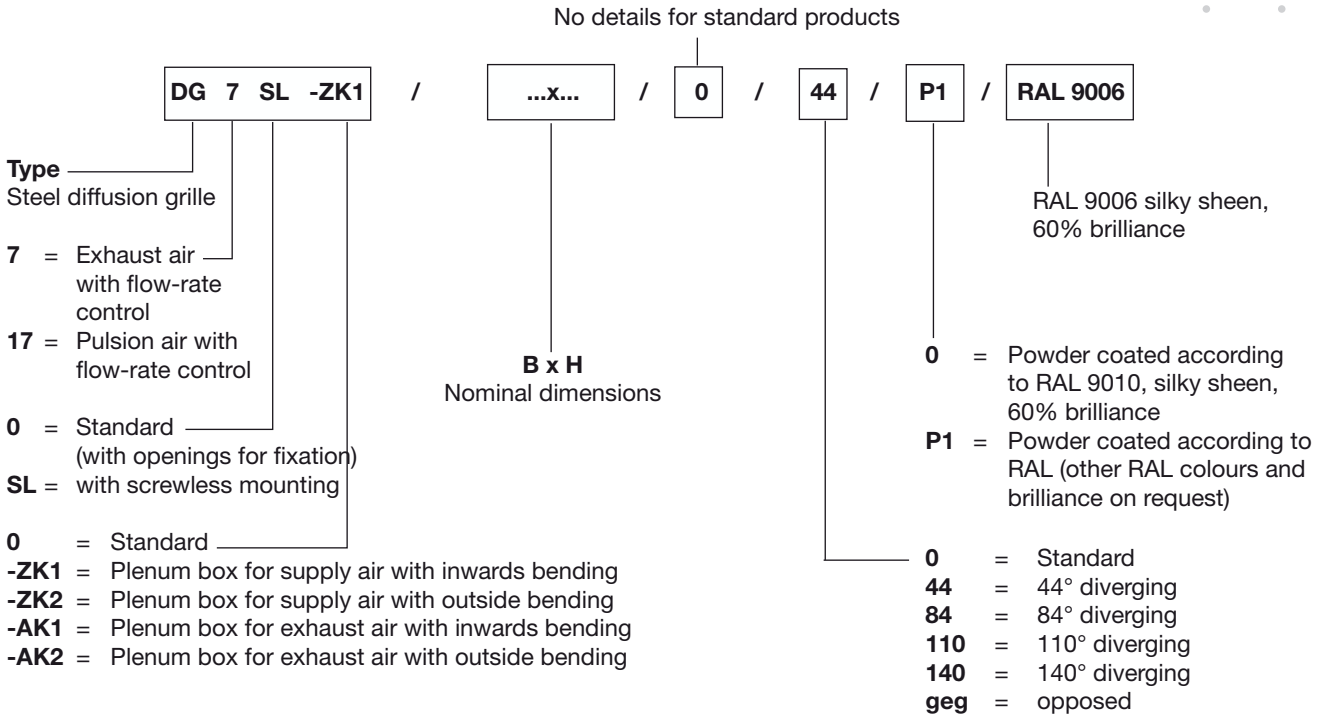

Order examples

35 off DG17 -ZK1 / 600 x 100 / 44 / P1 / RAL9006
 25 off DG7 SL -AK1 / 900 x 200

Text for tendering purposes

Type DG17

Diffusion grille (supply air) with vertical (in front) and horizontal (behind) blades in streamlined form. Blades space 16.66 mm, dimension of the border 25 mm with gasket of foamed plastics, fastening by screw (sinkholes in the border). Deflector with baffle plate for flow-rate control mounted on back side.

Material

Grille: Steel powder coated RAL 9010, silky sheen, 60% brilliance.

Deflector: sendzimir-galvanized steel

Type DG7

Diffusion grille with vertical blades in streamlined form. Blades space 16.66 mm, dimension of the border 25 mm with gasket of foamed plastics, fastening by screw (sinkholes in the border). With screw-mounted damper consisting of coupled vertical countercurrent flaps. Deflector with baffle plate for flow-rate control mounted on back side.

Material

Grille: Steel powder coated RAL 9010, silky sheen, 60% brilliance.

Deflector: sendzimir-galvanized steel