

# Diffusion grilles

Type DGVAR

Description of systems

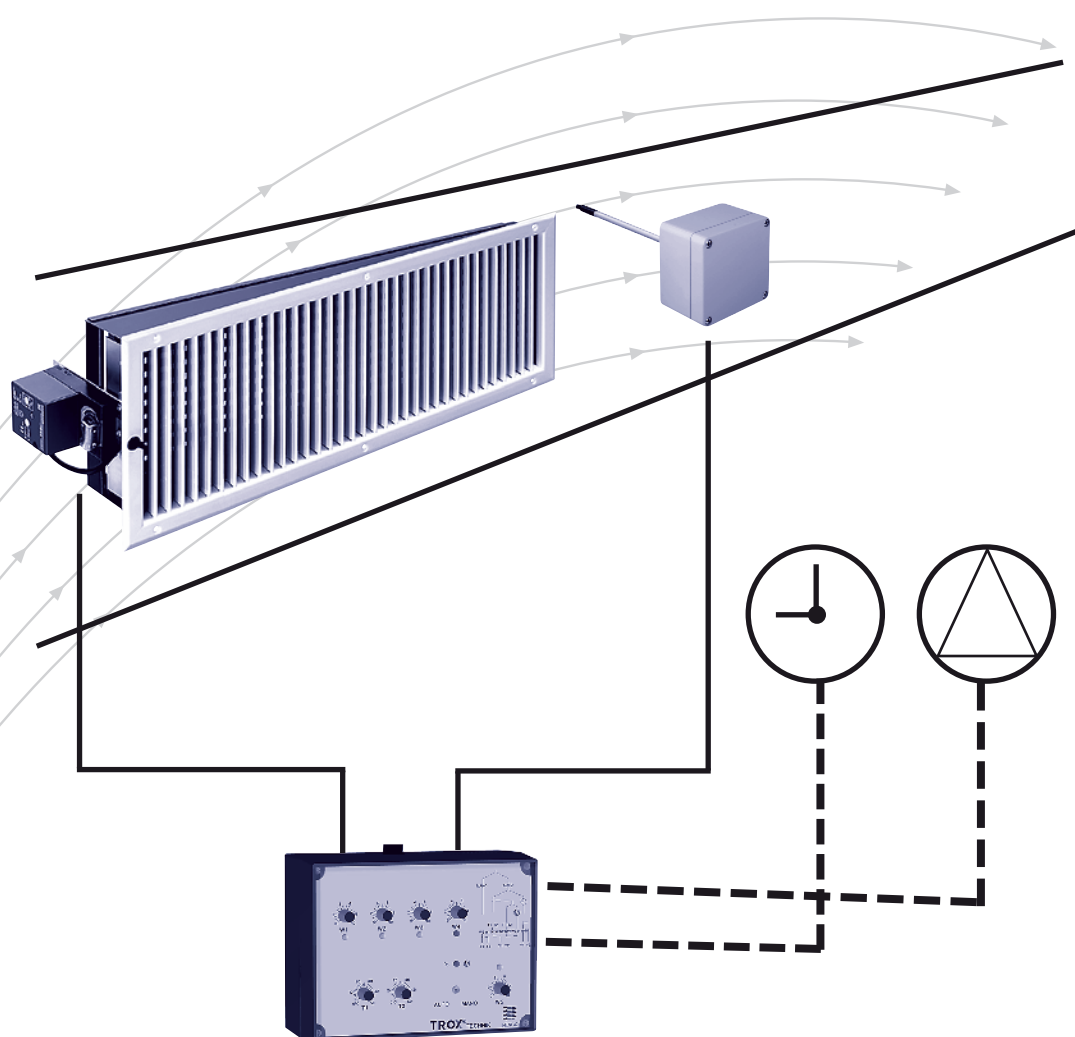

**TROX<sup>®</sup> TECHNIK**



TROX HESCO Schweiz AG  
Walderstrasse 125  
Postfach 455  
CH - 8630 Rüti /ZH

Tel. +41 (0)55 250 71 11  
Fax +41 (0)55 250 73 10  
[www.troxhesco.ch](http://www.troxhesco.ch)  
[info@troxhesco.ch](mailto:info@troxhesco.ch)

# Contents

1.	Diffusion grille DGVAR for temperature controlled direction of air jet	3	5.	DGVAR installation and start-up	20
2.	DGVAR air diffusion systems	4	5.1	Installation of air outlets	20-21
2.1	Temperature-dependent control of DGVAR air outlets by means of KTF2VAR duct temperature sensor and STG2VAR control unit <b>Standard DGVAR-System with</b> time-switch and rapid warm-up	4-5	5.2	Miscellaneous electro-technical hints	22
2.2	Temperature-dependent control of DGVAR air outlets by means of KTF2VAR duct temperature sensor and STG2VAR control unit <b>Standard DGVAR-System with</b> time-switch and rapid warm-up <b>for 2-stage installations</b>	6-7	5.2.1	Installation 24 Volts	22
2.3	Temperature-dependent control of DGVAR air outlets by means of KTF2VAR duct temperature sensor and STG2VAR control unit <b>Standard DGVAR-System with</b> time-switch a. rapid warm-up <b>for 2-stage installations, with PAS2VAR</b>	8-9	5.2.2	Transformator	22
2.4	Temperature-dependent control of DGVAR air outlets by means of KTF2VAR duct temperature sensor and STG2VAR control unit <b>DGVAR-System without</b> time-switch, <b>without</b> rapid warm-up	10-11	5.2.3	Supply wiring	22
3.	Different kind of air diffusion with DGVAR air outlets	12	5.3	Installation of the electro-technical apparatus	23
3.1	Manual control of DGVAR air outlets by means of SGA2VAR position indicator	12	5.3.1	Control unit type STG2VAR	23
3.2	Utilisation of diffusion grilles DGVAR...AZ with override regulation "open-closed"	13	5.3.2	Duct temperature sensor type KTF2VAR	23
4.	Electro-technical component data	14	5.3.3	Position indicator type SGA2VAR	23
4.1	Adjustment drive (motor of DGVAR)	14	5.4	Start-up of an installation	24
4.2	Control unit type STG2VAR	15-17	5.4.1	Position of blades in relation to the STG2VAR	24
4.3	Duct temperature sensor type KTF2VAR	18	5.4.2	Temperature-dependent control of DGVAR ventilation supply air outlets using the KTF2VAR duct temperature sensor and STGVAR control unit	24
4.4	Adder-subtractor type PAS2VAR	18	5.4.3	Manual control of DGVAR ventilation outlets using SGA2VAR position indicator	25
4.5	Position indicator type SGA2VAR	19	6.	Summary and important notes concerning the DGVAR-system (planning notes)	26
				Prospectus, see L-02-3-01e	
				Aeraulics data, see L-02-5-01e	

## 1. Diffusion grille DGVAR which directs the jet of air according to the temperature (see prospectus L-02-3-01e)

The DGVAR is applied for energy-saving air-conditioning installations in halls (e.g. exhibition halls, workshops, gymnasiums, stores etc.) where, in addition to an effective distribution of air and the elimination of stratification due to the temperature gradient, it is important that comfort be maintained at all service points or work stations in the installation.

The DGVAR diffusion grille is an air-conditioning supply air outlet in which the horizontal air-directing blades are adjusted by motor depending on the temperature of the supply air. If the supply temperature of the conditioning air is higher than ambient temperature (heating mode) the jet is directed downwards into the public area, in cooling mode the jet is raised.

With the DGVAR the horizontal blades can be turned until the grille is closed. This facility can be used in multi-stage installations to close a predetermined number of grilles using a reduced air flow. In this way the grilles which remain open are more heavily loaded, i.e. almost the same air velocity will be produced as when the full air volume is in use.

**During the warm-up phase (the period during which the space contains no people), some of the grilles are closed but full air volume is used.** This means that in case the grilles which are blowing (the open grilles) the air velocity and induction are considerably increased. The air jet is directed downwards with the result that the warm-up time is shortened and the temperature stratification in the space substantially reduced.

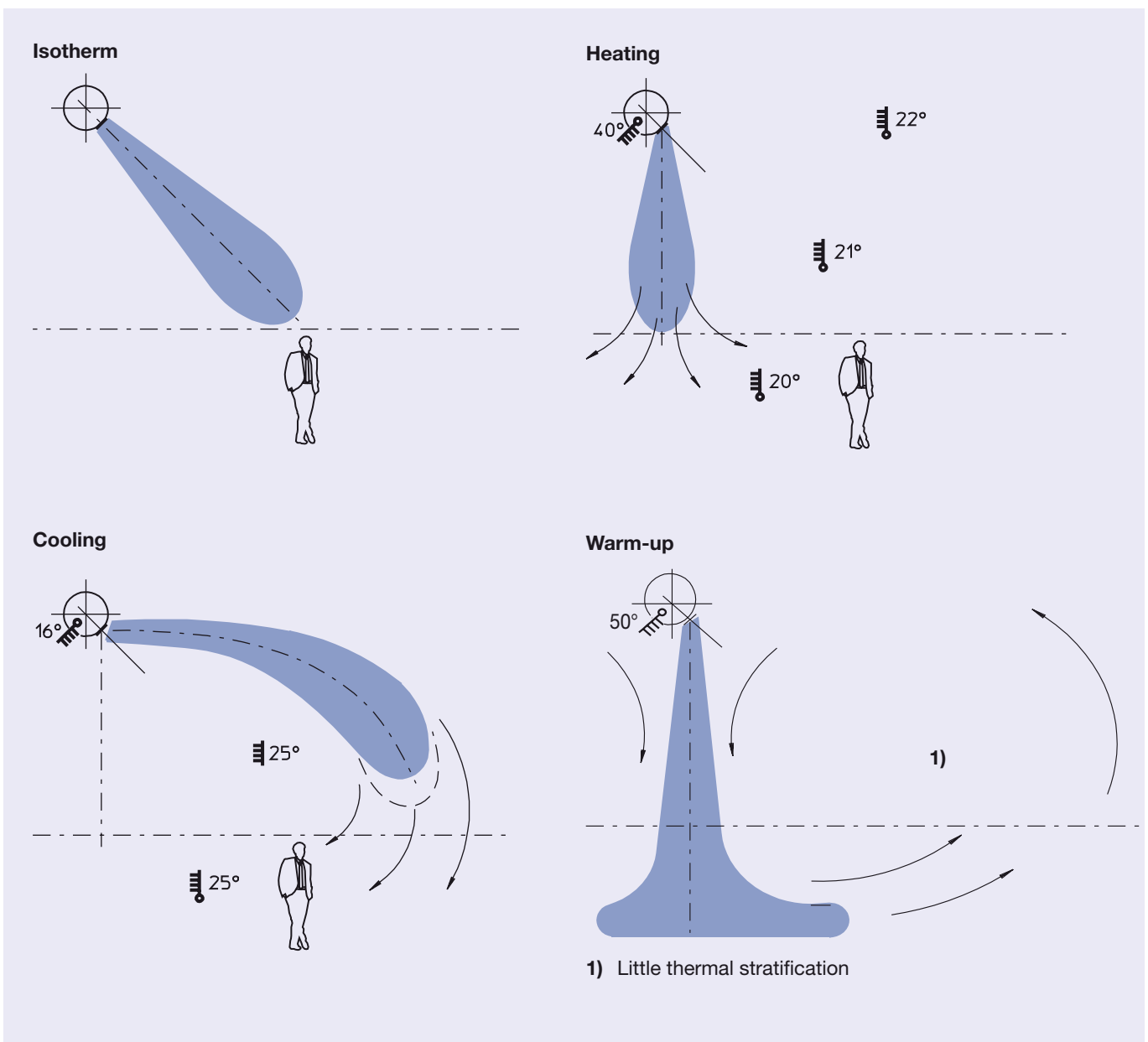

## 2. DGVAR air diffusion systems

### 2.1 Temperature-dependent control of DGVAR air outlets by means of KTF2VAR duct temperature sensor and STG2VAR control unit

(standard DGVAR-System , with time-switch, with rapid warm-up, min. 4-core connection cable)

#### Basic setting on the control unit

The direction of the jet is adjusted on the control unit (3) by means of the setting controls W1, W2, W3. The currently active setting control is indicated by the LED (see "front panel of control unit", page 16).

The temperature in the duct is measured by the temperature sensor (9). The required temperature values T1 and T2 are entered on the control unit (3).

If the temperature in the duct is lower than the set value T1, the DGVAR (1) are controlled by the setting control W1. This is normally set so that the air jet is directed upwards (cooling mode).

If the temperature is between the two set values T1 and T2, the DGVAR (1) are controlled by the setting control W2. This is normally set so that the air jet is blown out horizontally (isothermal).

If the temperature is above the set value T2, the DGVAR (1) are controlled by the setting control W3. This is normally set so that the air jet is directed downwards (heating mode).

Up to 100 DGVAR outlets can be controlled by the control unit (3). An on-site 24-volt transformer ensures power supply to the drives. The output of the transformer must be calculated as a function of the number of drives (transformer calculation specifications see page 22).

#### Manual adjustment on the control unit

Temperature-dependent control (AUTO) can be switched over on the control unit (3) to manual (MANO) by means of change-over switches. The desired blowing position is then adjusted by means of setting control W5, which is indicated by a green LED.

#### Rapid warm-up using on-site time switch

During the warm-up phase, a proportion of the DGVAR (1) can be closed by means of a time switch. The remaining DGVAR (1) then, independently of the temperature, blow the air downwards into the public area at higher speed. The desired blowing position is then adjusted by means of setting control W4, which is indicated by a red LED.

#### Outline diagram

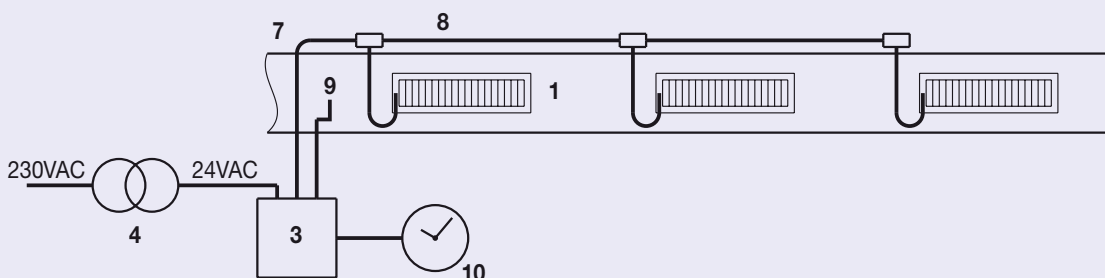

- 1** DGVAR air outlet <sup>1)</sup>
- 3** STG2VAR control unit
- 4 Transformer
- 5 Fuses as recommended by transformer manufacturer
- 6 ON switch for installation, or ventilator auxiliary switch
- 7 Electricity support cable Td 4 x1,5 mm<sup>2</sup> (Td 5 x1,5 mm<sup>2</sup>)
- 8 Flat ribbon cable (recommendation 5-core)  
(e.g. by Woertz of Basle)
- 9** KTF2VAR duct temperature sensor
- 10 Time switch

Positions printed in bold face = supplied by TROX HESCO

**1) Important indication**

DGVAR diffusion grilles in the **same** duct has to be connected alternately to Y<sub>1</sub> (11) and Y<sub>2</sub> (12).

Connection diagram

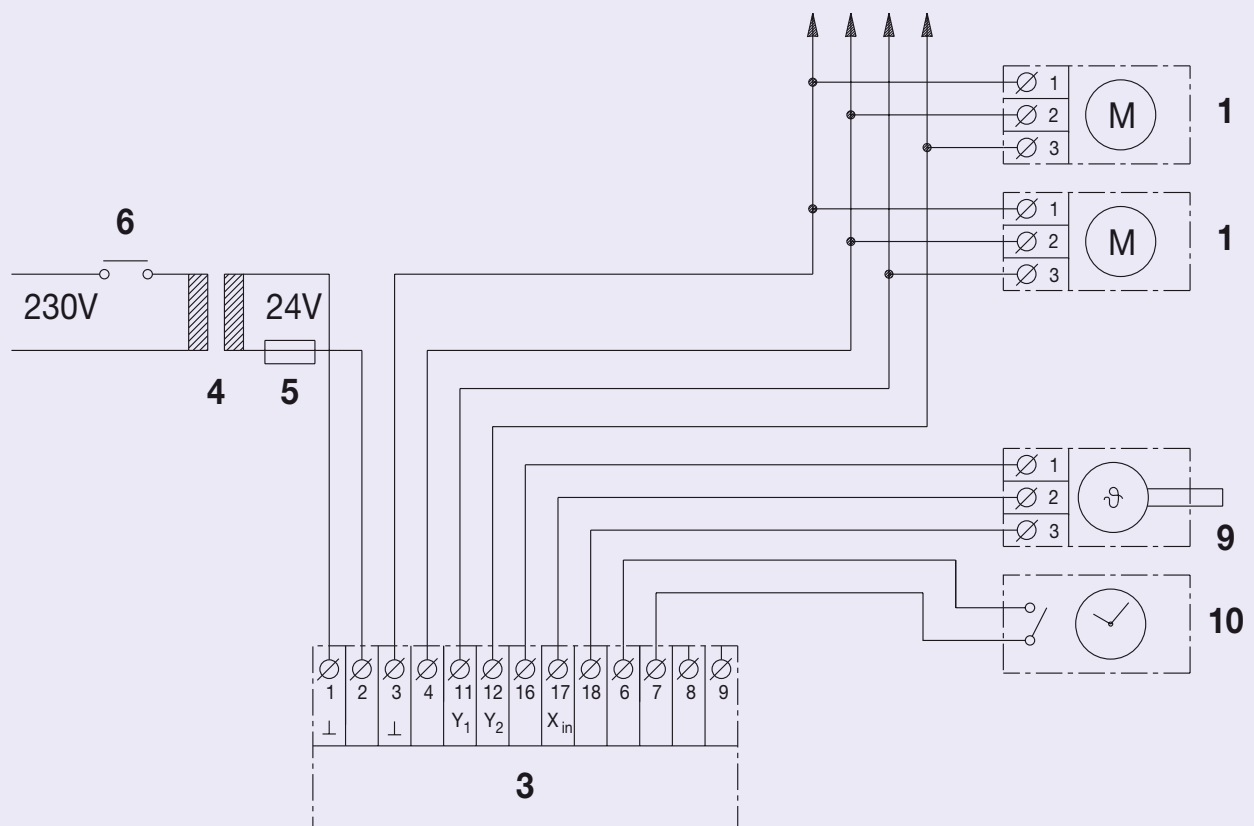

## 2.2 Temperature-dependent control of DGVAR air outlets by means of KTF2VAR duct temperature sensor and STG2VAR control unit (standard DGVAR-System , **with** time-switch, **with** rapid warm-up, min.4-core connection cable, **for 2-stage installations**)

### Basic setting on the control unit

The direction of the jet is adjusted on the control unit (3) by means of the setting controls W1, W2, W3. The currently active setting control is indicated by the LED (see "front panel of control unit", page 16).

The temperature in the duct is measured by the temperature sensor (9). The required temperature values T1 and T2 are entered on the control unit (3).

If the temperature in the duct is lower than the set value T1, the DGVAR (1) are controlled by the setting control W1. This is normally set so that the air jet is directed upwards (cooling mode).

If the temperature is between the two set values T1 and T2, the DGVAR (1) are controlled by the setting control W2. This is normally set so that the air jet is blown out horizontally (isothermal).

If the temperature is above the set value T2, the DGVAR (1) are controlled by the setting control W3. This is normally set so that the air jet is directed downwards (heating mode).

Up to 100 DGVAR outlets can be controlled by the control unit (3). An on-site 24-volt transformer ensures power supply to the drives. The output of the transformer must be calculated as a function of the number of drives (transformer calculation specifications see page 22).

### Manual adjustment on the control unit

Temperature-dependent control (AUTO) can be switched over on the control unit (3) to manual (MANO) by means of change-over switches. The desired blowing position is then adjusted by means of setting control W5, which is indicated by a green LED.

### Rapid warm-up using on-site time switch

During the warm-up phase, a proportion of the DGVAR (1) can be closed by means of a time switch. The remaining DGVAR (1) then, independently of the temperature, blow the air downwards into the public area at higher speed. The desired blowing position is then adjusted by means of setting control W4, which is indicated by a red LED.

### Reduced air-flow through the ventilator

In a 2-stage installation, in the lower stage (reduced air volume), it is possible through the use of an auxiliary contactor (13) to close for example half of the total number of the DGVAR (1). The remaining DGVAR continue to be controlled as a function of temperature by the setting values of the setting controls W1, W2, W3 and the set values of T1 and T2. If an installation has both 2-stage ventilators and rapid warm-up, the same DGVAR close for reduced air-flow through the ventilator as for rapid warm-up.

### Outline diagram

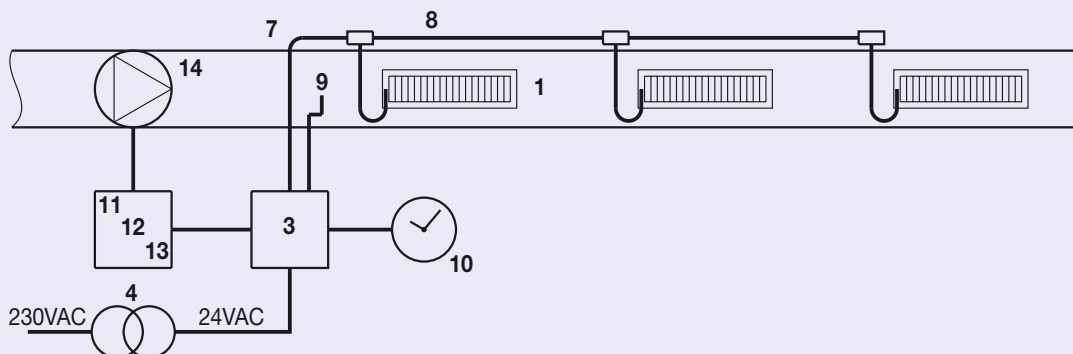

- 1** DGVAR air outlet <sup>1)</sup>
  - 3** STG2VAR control unit
  - 4** Transformator
  - 5** Fuses as recommended by transformer manufacturer
  - 6** ON switch for installation, or ventilator auxiliary switch
  - 7** Electricity support cable Td 4 x1,5 mm<sup>2</sup> (Td 5 x1,5 mm<sup>2</sup>)
  - 8** Flat ribbon cable (recommendation 5-core)  
(e.g. by Woertz of Basle)
  - 9** KTF2VAR duct temperature sensor
  - 10** Time switch
  - 11** Control trip-switch stage II
  - 12** Control trip-switch stage I
  - 13** Auxiliary trip-switch stage I
  - 14** Ventilator
- Positions printed in bold face = supplied by TROX HESCO**

**1) Important indication**

DGVAR diffusion grilles in the **same** duct has to be connected alternately to Y<sub>1</sub> (11) and Y<sub>2</sub> (12).

**Connection diagram**

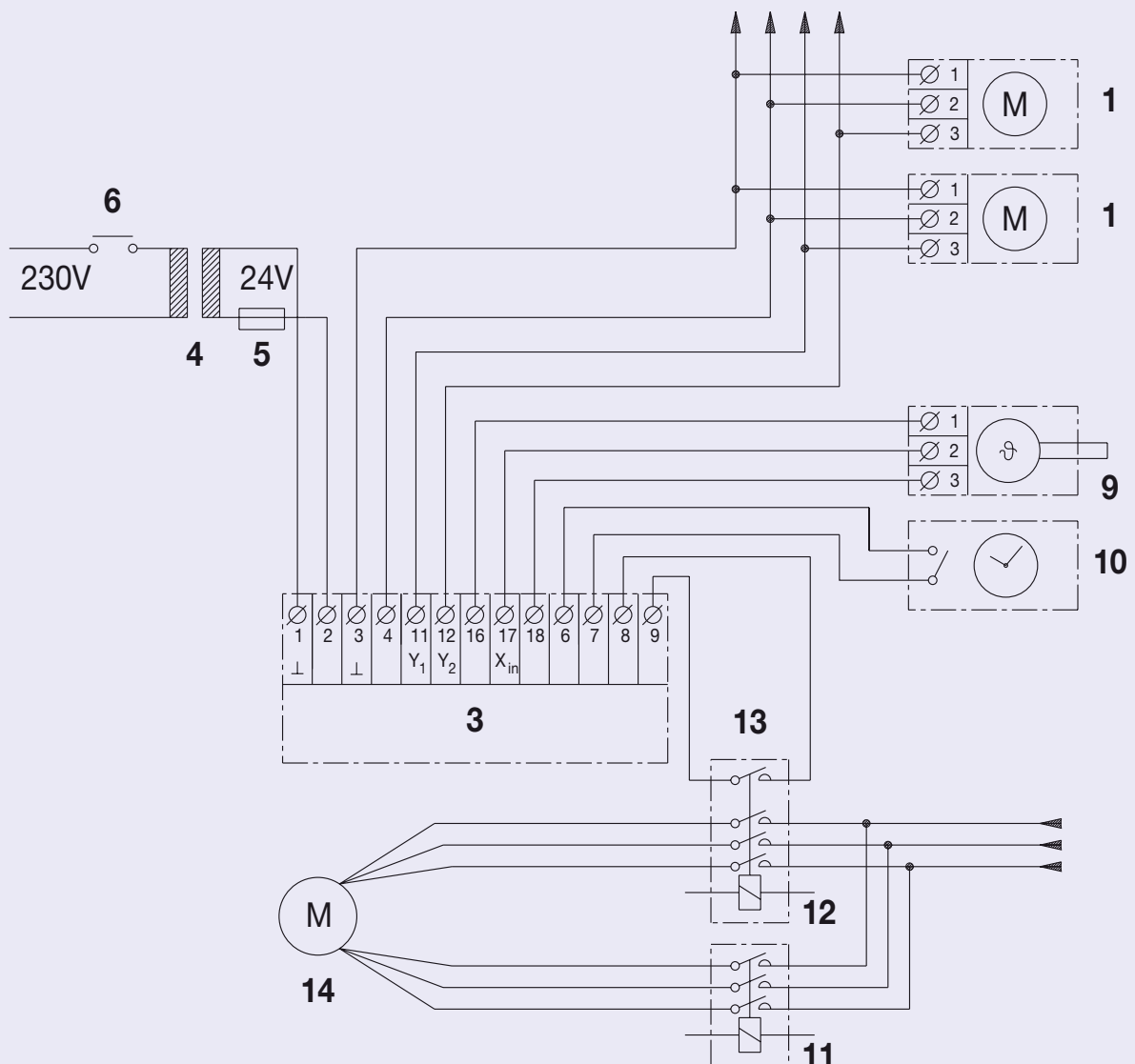

## 2.3 Temperature-dependent control of DGVAR air outlets by means of KTF2VAR duct temperature sensor and STG2VAR control unit

(standard DGVAR-System , with time-switch, with rapid warm-up, 5-core connection cable, for 2-stage installations, with PAS2VAR )

### Description see textes page 6

Basic setting on the control unit

Manual adjustment on the control unit

Rapid warm-up using on-site time switch

Reduced air-flow through the ventilator

### Application and functioning of the potentiometer "Adder - Subtractor" PAS2VAR

The PAS2VAR „Adder - Subtractor“ is a supplementary unit, which can supplement all DGVAR system variants described on pages 4 – 7. It is used, when the jet of fresh air is to blow at an offset angle from one or more DGVAR air outlets towards the other DGVAR diffusion grilles.

In order that this supplementary function shall be able to be introduced, it is essential to have available a 5-core connection cable leading from the control unit as far as the connection boxes of the DGVAR air outlets.

The air jet can be blown at an offset angle, at a maximum angle of approximately 30° (on the potentiometer, this corresponds to  $\pm 2$  VDC).

Its practical advantages are manifold as, for example, in the case of later construction-related alterations such as the incorporation of galleries, crane rails, cross-rails, girders and the like, where it is possible to "blow round" these interfering objects, thereby avoiding draught phenomena and improving the efficiency of ventilation.

In this way, comfort in exposed places of the zone can be improved to an appreciable degree.

#### Note:

PAS2VAR adders - subtractors can also be fitted later, provided that a 5-core connection cable has been "laid" at the start.

### Outline diagram

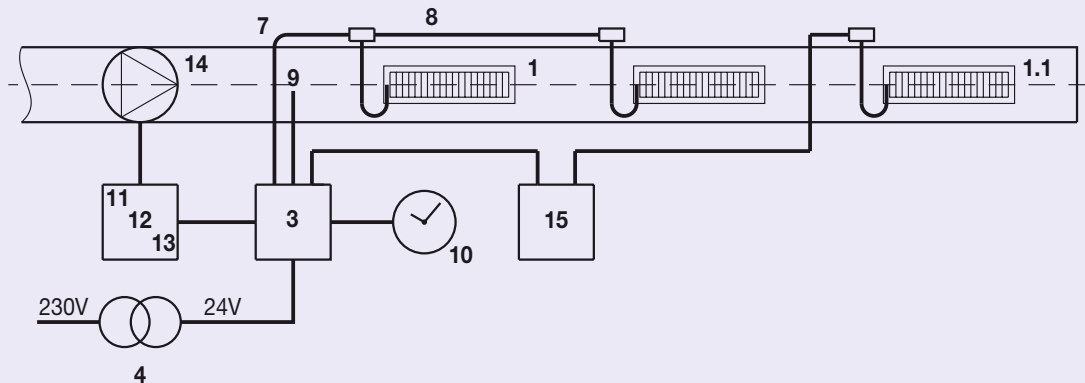

- 1 DGVAR air outlet** <sup>1)</sup>
- 1.1 DGVAR air outlet "influenced by PAS2VAR"**
- 3 STG2VAR control unit**
- 4 Transformer
- 5 Fuses as recommended by transformer manufacturer
- 6 ON switch for installation, or ventilator auxiliary switch
- 7 Electricity support cable Td 5 x 1,5 mm<sup>2</sup>
- 8 Flat ribbon cable (recommendation 5-core)  
(e.g. by Woertz of Basle)
- 9 KTF2VAR duct temperature sensor**
- 10 Time switch
- 11 Control trip-switch stage II
- 12 Control trip-switch stage I
- 13 Auxiliary trip-switch stage I
- 14 Ventilator
- 15 Adder - Subtractor PAS2VAR

**1) Important indication:**

DGVAR diffusion grilles in the **same** duct has to be connected alternately to Y<sub>1</sub> (11) and Y<sub>2</sub> (12).

**Positions printed in bold face = supplied by TROX HESCO**

**Connection diagram**

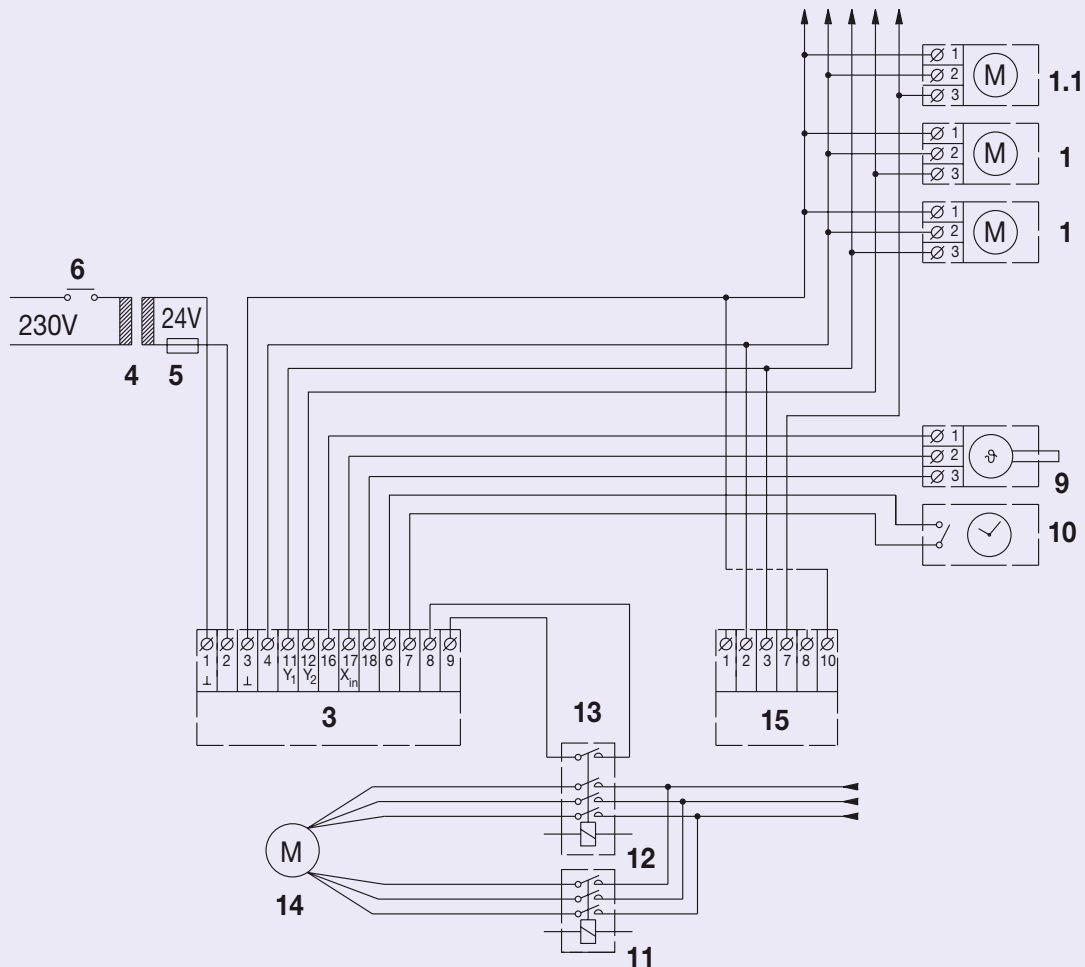

## 2.4 Temperature-dependent control of DGVAR air outlets by means of KTF2VAR duct temperature sensor and STG2VAR control unit

DGVAR-System, **without** time-switch, **without** rapid warm-up, min. 3-core connection cable (**not** a real DGVAR-System)

### Basic setting on the control unit

The direction of the jet is adjusted on the control unit (3) by means of the setting controls W1, W2, W3. The currently active setting control is indicated by the LED (see "front panel of control unit", page 16).

The temperature in the duct is measured by the temperature sensor (9). The required temperature values T1 and T2 are entered on the control unit (3).

If the temperature in the duct is lower than the set value T1, the DGVAR (1) are controlled by the setting control W1. This is normally set so that the air jet is directed upwards (cooling mode).

If the temperature is between the two set values T1 and T2, the DGVAR (1) are controlled by the setting control W2. This is normally set so that the air jet is blown out horizontally (isothermal).

If the temperature is above the set value T2, the DGVAR (1) are controlled by the setting control W3. This is normally set so that the air jet is directed downwards (heating mode).

Up to 100 DGVAR outlets can be controlled by the control unit (3). An on-site 24-volt transformer ensures power supply to the drives. The output of the transformer must be calculated as a function of the number of drives (transformer calculation specifications see page 22).

### Manual adjustment on the control unit

Temperature-dependent control (AUTO) can be switched over on the control unit (3) to manual (MANO) by means of change-over switches. The desired blowing position is then adjusted by means of setting control W5, which is indicated by a green LED.

### Outline diagram

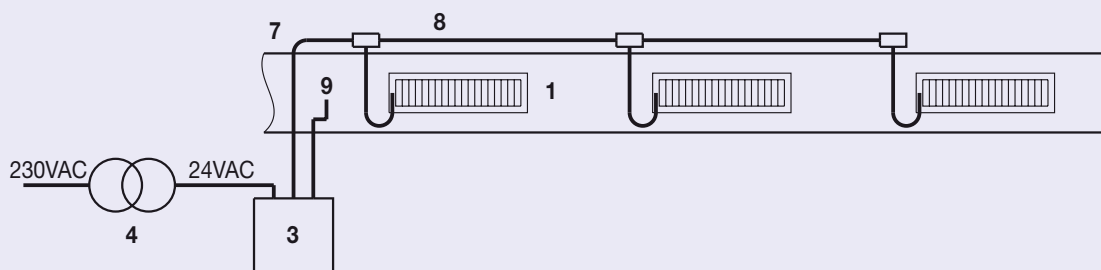

- 1** DGVAR air outlet <sup>1)</sup>
- 3** STG2VAR control unit
- 4 Transformer
- 5 Fuses as recommended by transformer manufacturer
- 6 ON switch for installation, or ventilator auxiliary switch
- 7 Electricity support cable Td 3 x1,5 mm<sup>2</sup> (Td 5 x1,5 mm<sup>2</sup>)
- 8 Flat ribbon cable (recommendation 5-core)  
(e.g. by Woertz of Basle)
- 9** KTF2VAR duct temperature sens

Positions printed in bold face = supplied by TROX HESCO

Connection diagram

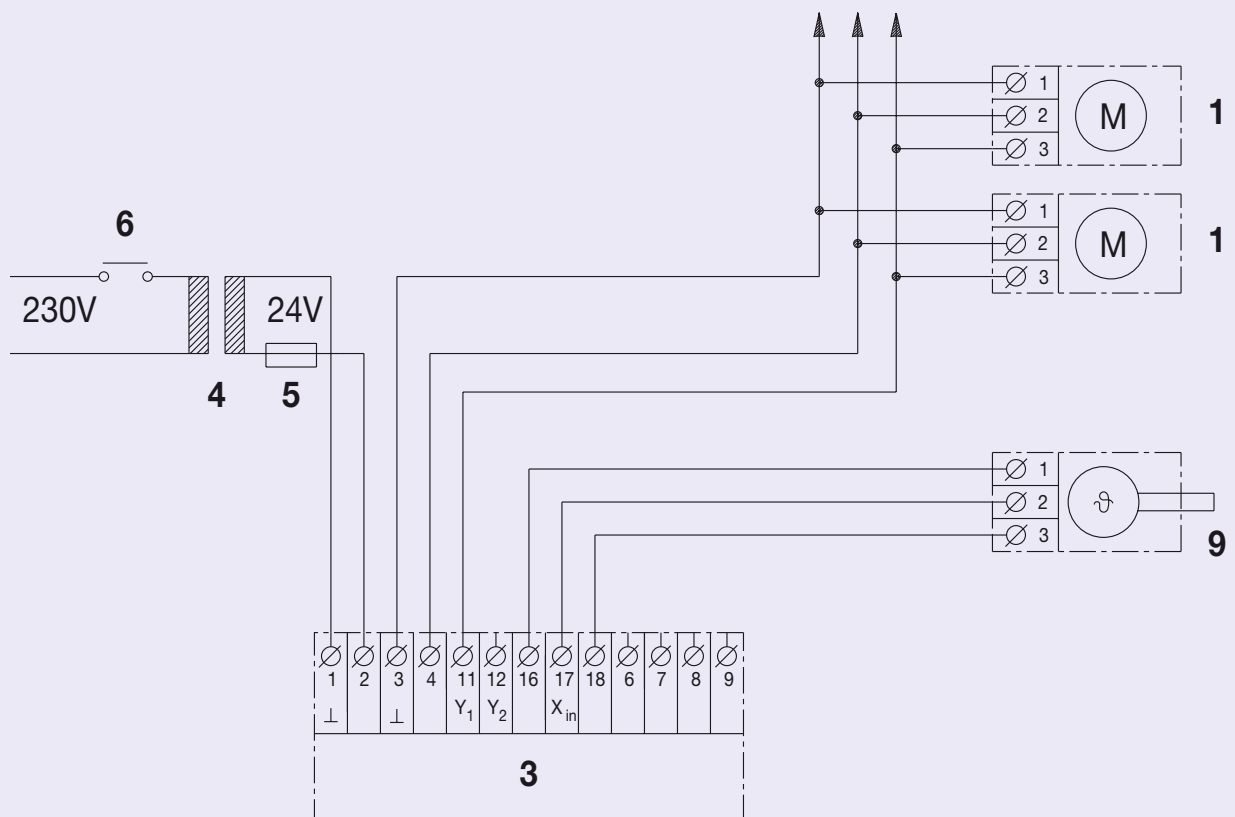

# Technical Data

## 3. Different kind of air diffusion with DGVAR air outlets

### 3.1 Manual control of DGVAR air outlets by means of SGA2VAR position indicator

(manual control, min. 3-core connection cable)

#### Description:

The blades of the DGVAR (1) are adjusted manually by means of the position indicator (2) to the desired supply air angle. In position 0 the grilles are closed. In position 6 (black point) the blades are opened 100%. (In position ~ 8.3, the blades will have reached their maximum angle of rotation).

#### Attention:

In position 0, the grilles are closed. The static pressure in the channel is to be controlled via pressure transmitters and the fan output is to be reduced. If these instructions are not complied with, we shall not be responsible for the cost of repair of any resulting damage (e.g. duct distension).

The position indicator (2) can be used to control up to 100 DGVAR (1). An on-site 24 V transformer (4) ensures power supply to the drive.

The output of the transformer (4) must be calculated as a function of the number drives. (Transformer calculation specification see page 22).

- 1 DGVAR air outlet**
- 2 SGA2VAR position indicator**
- 4 Transformer**
- 5 Fuses as recommended by transformer manufacturer**
- 6 ON switch for installation, or ventilator auxiliary switch**
- 7 Electricity support cable Td 3 x 1,5 mm<sup>2</sup> (Td 5 x 1,5 mm<sup>2</sup>)**
- 8 Flat ribbon cable (recommendation 5-core)**  
(e.g. by Woertz of Basle)

**Positions printed in bold face = supplied by TROX HESCO**

#### Outline diagram

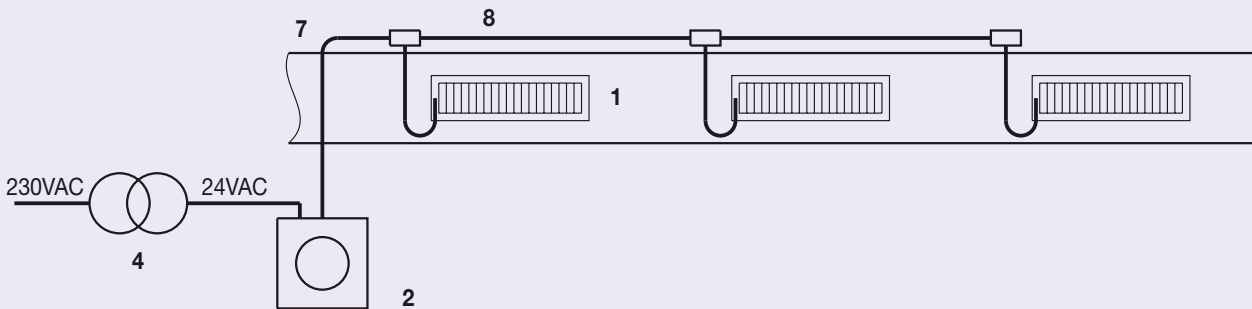

#### Connection diagram

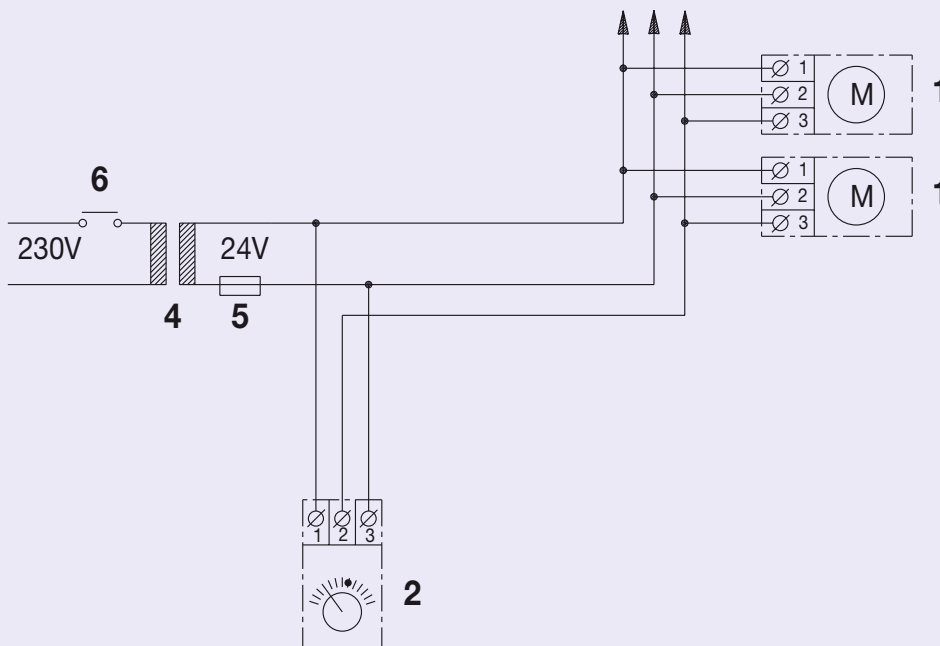

### 3.2 Utilisation of diffusion grilles DGVAR...AZ with override regulation "open - closed"

Angle of rotation of the motor: 60° (angle of blades = 90°)

**Attention:** Depending to the type of application, the static pressure in the channel is to be controlled via pressure transmitters and the fan output is to be reduced. If these instructions are not complied with, we shall not be responsible for the cost of repair of any resulting damage (e.g. duct distension).

Connection diagram

1 off DGVAR...AZ

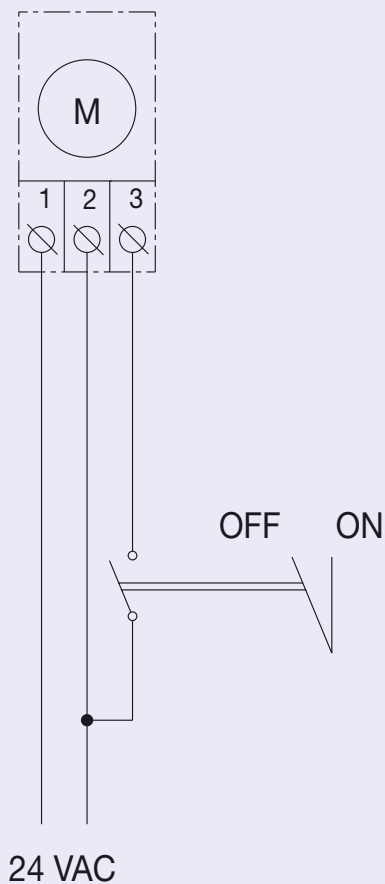

Connection diagram

2 or more off DGVAR...AZ

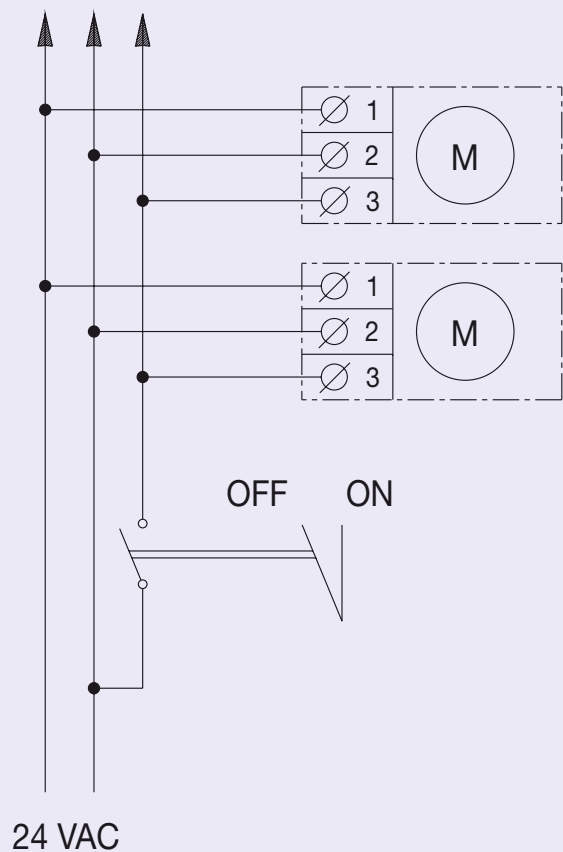

# Technical Data

## 4. Electro-technical component data

### 4.1 Adjustment drive (TROX HESCO motor type: DGM06)



#### Technical data:

Nominal voltage:	AC 24 V, 50/60 Hz
Control voltage: (Setting signal)	DC 0 ... 10 V
Dimension:	4 VA
Consumption:	1.5 W at the nominal moment (For transformer calculation, see data under 'Transformer', page 22)
Running	90 sec
Ambient temperature:	- 30 jusqu'à + 50 °C
Protection type:	IP 54

#### Connection diagram

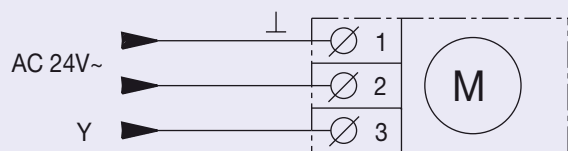

#### Note:

The DGVAR type DGM06 actuating drive is an integral part of the DGVAR air outlets. The DGVAR diffusion grilles and the actuating drive are **always supplied assembled** (works tested). Actuating drives **cannot be supplied** without DGVAR diffusion grilles.

## 4.2 STG2VAR control unit

### Technical data:

Supply voltage:	24 VAC~ ± 20%, 50 Hz
Consumption:	2 W
Ambient temperature:	0 to 40 °C
Structural form:	in 2 parts

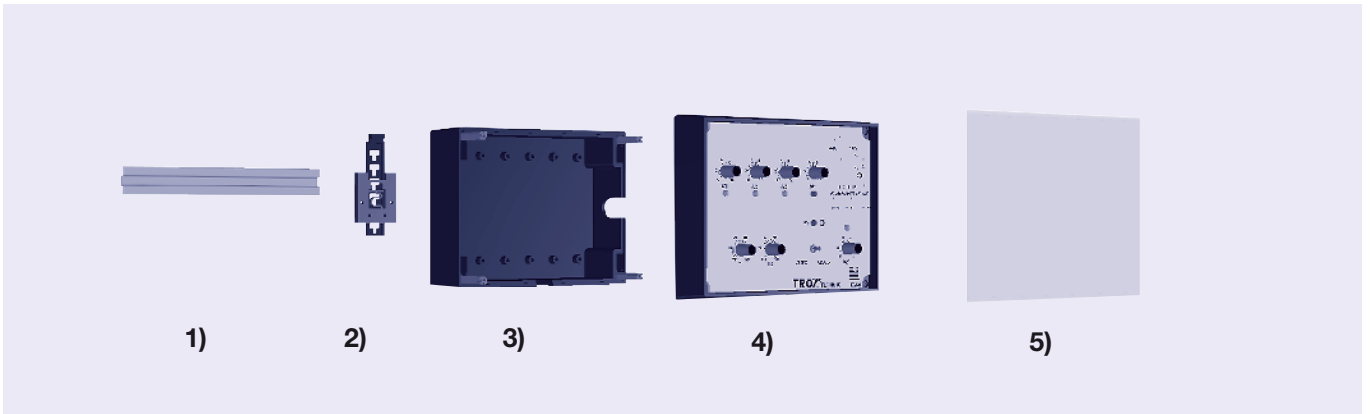

- 1) DIN Specification rail
- 2) Fixing clip (screwed on in position 3)
- 3) Rear part of housing
- 4) Front part of housing, including control
- 5) Control unit cover (Plexiglas)

- 1) DGVAR air outlets

### Important indication:

DGVAR diffusion grilles in the same duct has to be connected alternately to Y<sub>1</sub> (11) and Y<sub>2</sub> (12).





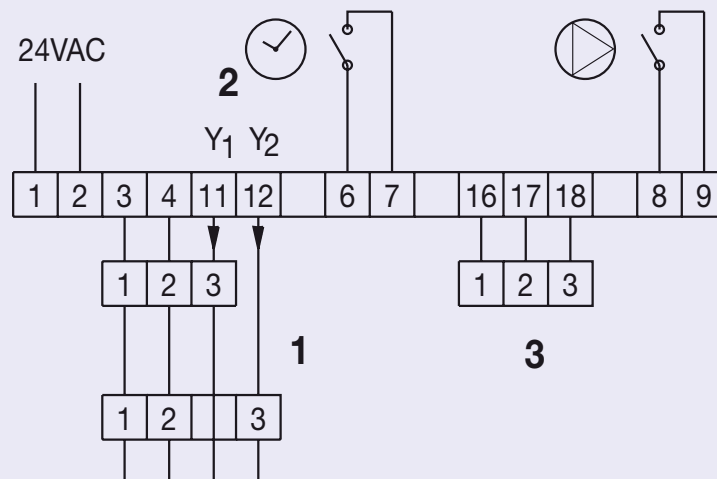











- 2) Exit Y1 (11) tension > 3 VDC !
- 3) KTF2VAR duct temperature sensor

### Connection diagram



# Technical Data

## Front panel of the STG2VAR control unit

-  W1 = Setting control 'cooling'
  -  W2 = Setting control 'isothermal'
  -  W3 = Setting control 'heating'
  -  W4 = Setting control 'rapid warm-up', 2-stage installation
  -  W5 = Position transmitter manual operation 'MANO'
  -  T1 = Set value potentiometer (cold air)
  -  T2 = Set value potentiometer (warm air)
  -  Symbol for time switch
-  Symbol for ventilator
  -  Green LED  
(signalisation of the transmitter by the position in action)
  -  Red LED
  -  Time clock contact 'closed'
  -  Auxiliary trip switch 'closed'
  -  Manual/automatic changeover switch
  -  Fixation screw
  -  Slats 'straight'

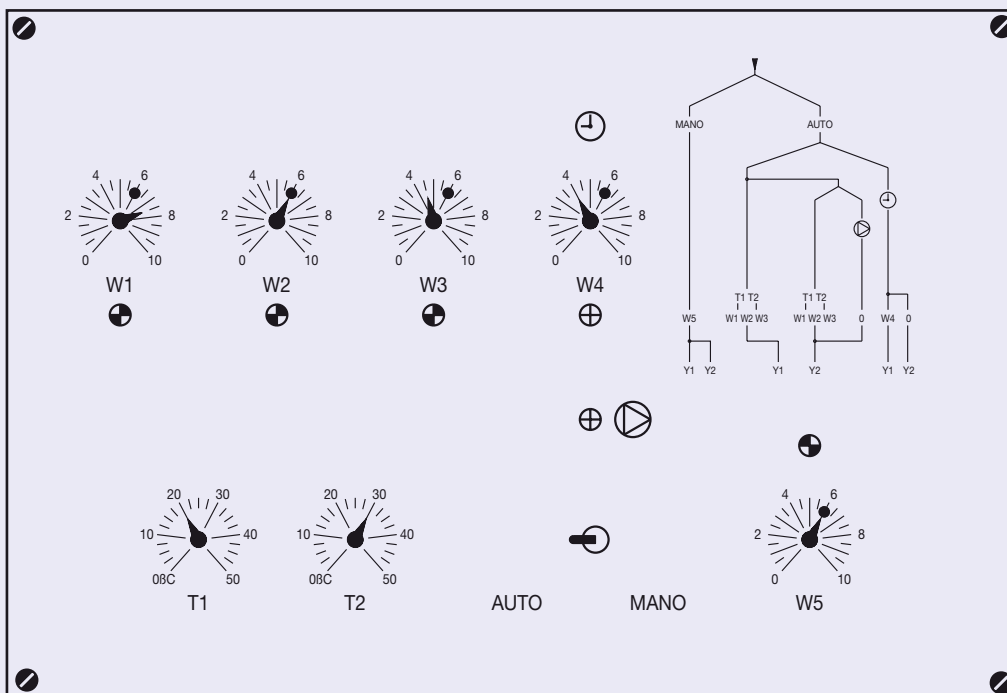

## Functions

### Switch in "Mano" position

- Setting control W5 in operation
- W5 LED lit (green)
- Y1 and Y2 have the same output signal

### Switch in "Auto" position

#### Time switch contact open, ventilator in 2nd stage (100%)

- Setting control W1, W2 or W3 in operation, depending on temperature and set temperature value
- W1, W2 or W3 LED lit, depending on which setting control is currently in operation
- Y1 and Y2 have the same output signal

#### Time switch contact open, auxiliary contactor of the ventilator 1st stage (red.) contact closed

For grilles connected to Y1:

- Setting control W1, W2 or W3 in operation, depending on temperature and set temperature value
- W1, W2 or W3 LED lit, depending on which setting control is currently in operation

For grilles connected to Y2:

- The DGVAR connected to this output close (control voltage=0)
- LED lit (red) 

#### Time switch contact closed: (rapid warm-up)

For grilles connected to Y1:

- Setting control W4 in operation
- W4 LED lit (red)

For grilles connected to Y2:

- The DG-VAR connected to this output close (control voltage=0)

## Notes

- If the time switch contact and the auxiliary contactor of the ventilator (stage 1) are closed, the time switch function has priority, i.e. the open DGVAR (connected to Y1) are not temperature dependent but go to the value set on setting control W4.
- If the control unit is switched to automatic, the installation nevertheless follows manual rules (green lamp on setting control W5 lit), the temperature settings T1 and T2 should be checked. Temperature value T2 may not be lower than temperature value T1.

# Technical Data

## 4.3 Duct temperature sensor type KTF2VAR

Construction: active probe  
 Supply voltage: 24 VAC  $\pm$  20%, 50 Hz  
 Output signal: 0 to 10 VDC  
 Temperature measurement range: 0 to +50 °C

### Description of use

As a general rule the KTF1VAR duct temperature sensor is always used together with an STG1VAR control unit. One duct temperature sensor can be installed per control unit. The temperature measured in the duct is converted into an electronic signal and transmitted to the control unit.

### Connection diagram

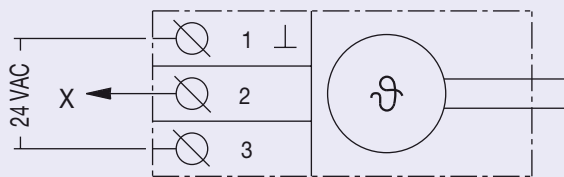
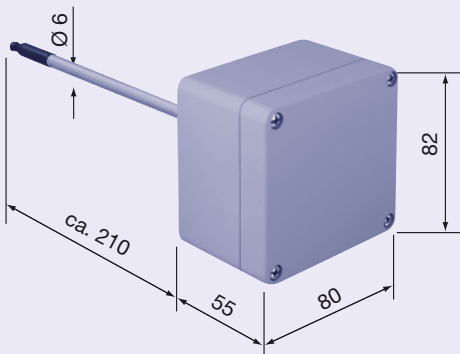

## 4.4 Adder-subtractor PAS2VAR

Supply voltage: 24 VAC  $\sim$   $\pm$  20%, 50 Hz  
 Consumption: 1 W  
 Input signal: 0 to 10 VDC  
 Output signal: 0 to 10 VDC  
 Ambient temperature: 0 to +50 °C

### Description of use

The PAS2VAR adder-subtractor is used in installations in which individual grilles are to come into operation earlier or later (requires 5-core cable, for example flat ribbon cable by Woertz, Basle). More details ( Outline and connection diagram) see page 8 + 9

### Connection diagram

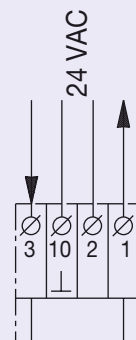
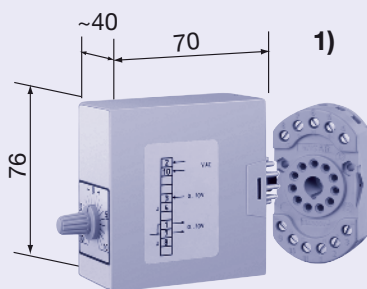

### 1) Socklet and DIN bar

Can be regulated by knob,  $\pm$ 2 volts, equivalent to about 30° angle of blades

## 4.5 SGA2VAR position indicator

Supply voltage:	24 VAC~ ± 20%, 50 Hz
Consumption:	1 W
Output signal:	0 to 10 VDC
Ambient temperature:	0 to + 40 °C

## Description of use

The blades of the DGVAR (1) are adjusted manually by means of the position indicator (2) to the desired supply air angle. In position 0 the grilles are closed. In position 6 (black point) the blades are opened 100%. The position indicator (2) can be used to control up to 100 DGVAR (1). An on-site 24 V transformer (4) ensures power supply to the drive.

The output of the transformer (4) must be calculated as a function of the number drives. (Transformer calculation specification see page 22).

## Connection diagram

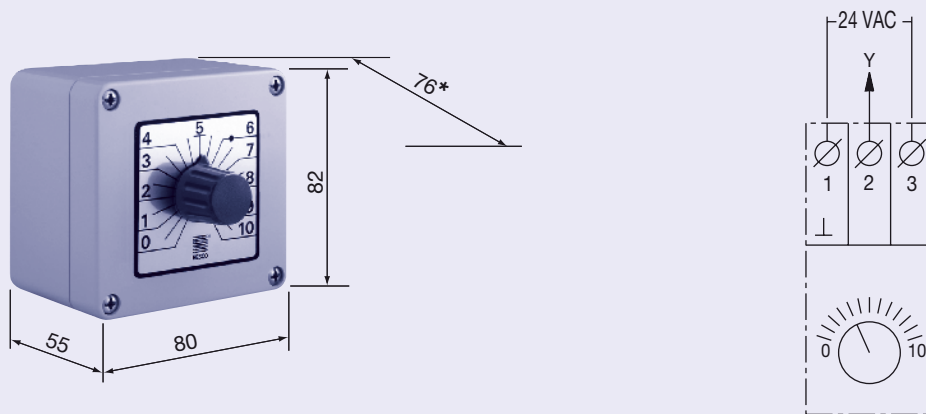

\*Total depth (with button)

## Outlet diagram

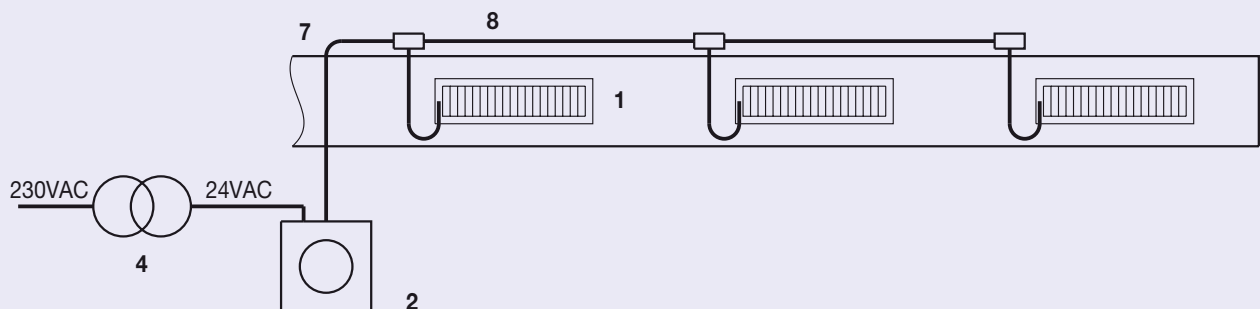

Connection diagram and legende see page 12

# Technical Data

## 5. DGVAR installation and start-up

### 5.1 Installation of the air outlets

The following mounting instructions should be followed:

#### a) Recess

#### b) maximum thickness of ceiling panel x, y, z:

DGVAR: **x** = max. 15 mm  
(with screw fixation MS)

DGLVAR: **y** = max. 8 mm  
(with clip SL)

DGRVAR: **z** = max. 3 mm  
(with clip SL)

DGRAVAR: **z** = max. 2 mm  
(with clip SL)

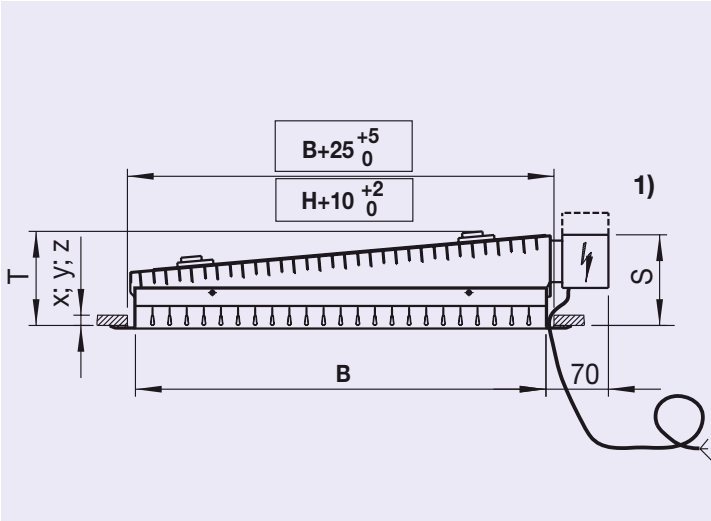

Nom.dim. <b>B</b> [mm]	<b>T</b> [mm]	Nom.dim. <b>H</b> [mm]	DGVAR <b>S 1)</b> [mm]	DGRVAR DGRAVAR <b>S 1)</b> [mm]
<b>600</b>	110	<b>100</b>	200	204
<b>750</b>	130	<b>150</b>	200	210
<b>900</b>	150	<b>200</b>	93	108
		<b>250</b>	93	113

1) for nom. dimension H = 100 + 150 mm  
(vertical drive)

#### c) Range of duct diameters for DGRVAR (DGRAVAR)

The following table shows for what duct diameter ranges the corresponding nominal grille height H can be used.

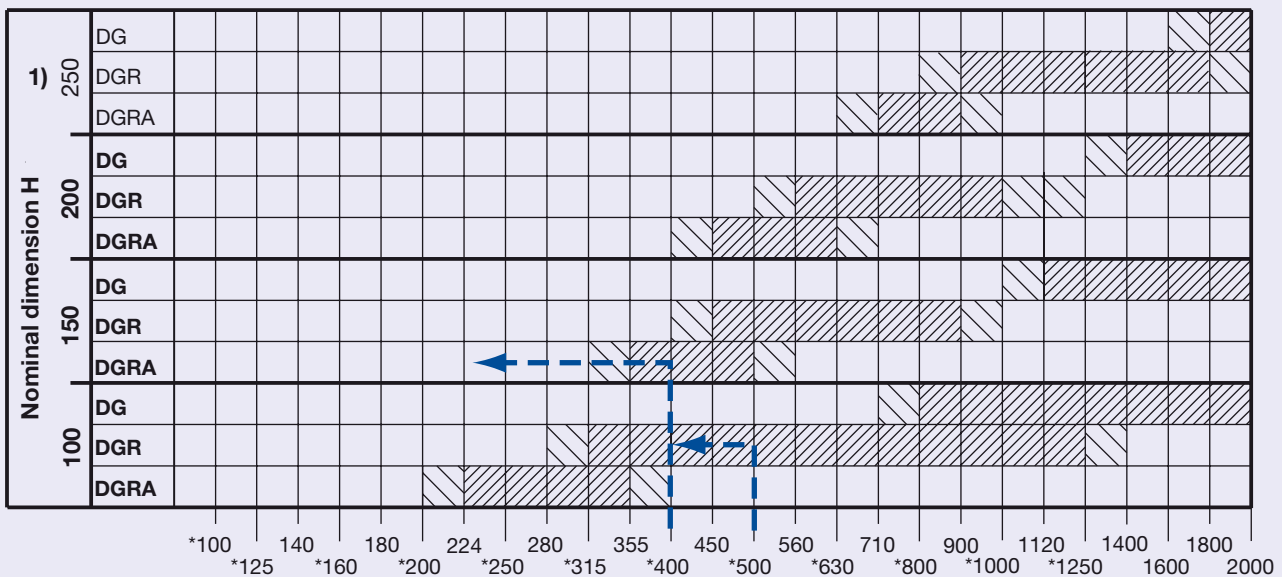

= extreme range  
 \* = duct diameter as per EN 1506 and EN 12220  
 (former: DIN 24 154 sheet 2 preference series)

1) Nom. dim. H = 100 + 150 mm (vertical drive)

## d) Installation of left and right grilles

Particular attention must be paid to correct installation of DGVAR5 (and also DGL and DGRVAR5). The air outlets indicated by a **red** label are for left-hand installation, as seen from the direction of air flow in the duct. Air outlets with a **green** label are intended for right-hand installation. Where the DGVAR is concerned, since it is fed from the back, care must be taken that the dummy blade is at the bottom.

Type LI (left grille)

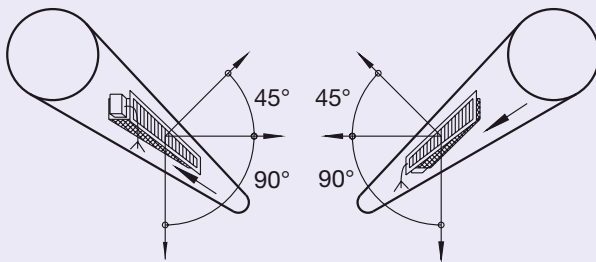

Type RE (right grille)

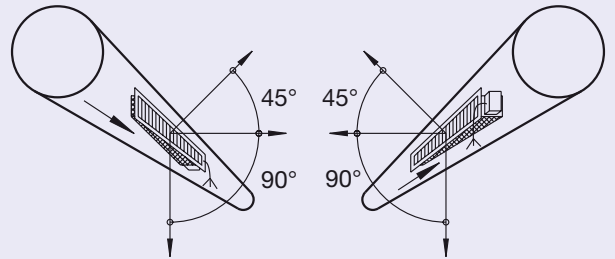

## Indications for the mounting

DGVAR5 LI

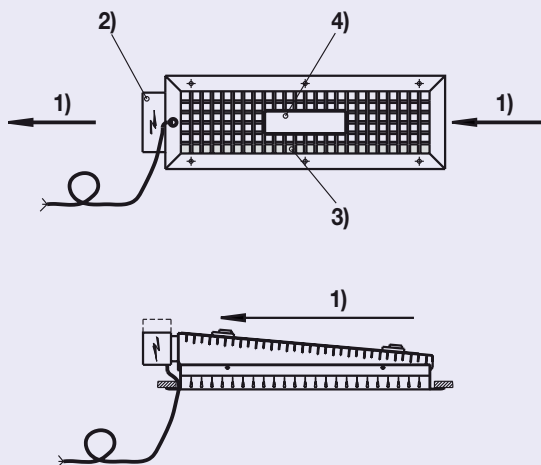

DGVA R5 RE

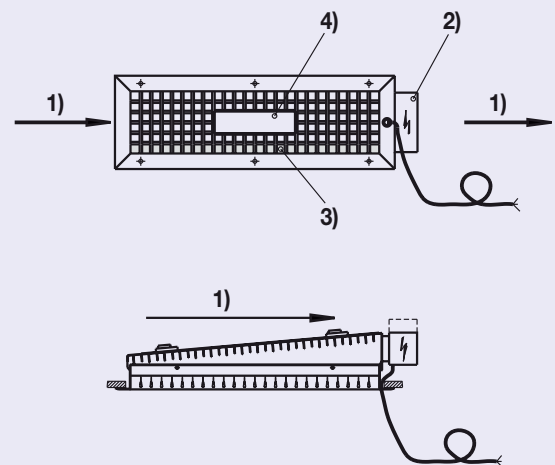

- 1) Direction of air in the duct
- 2) Adjustment drive
- 3) Blind blade "below"
- 4) Mounting description "red = LI",  
"green = RE" (please take away after mounting)

## 5.2 Various electro-technical hints

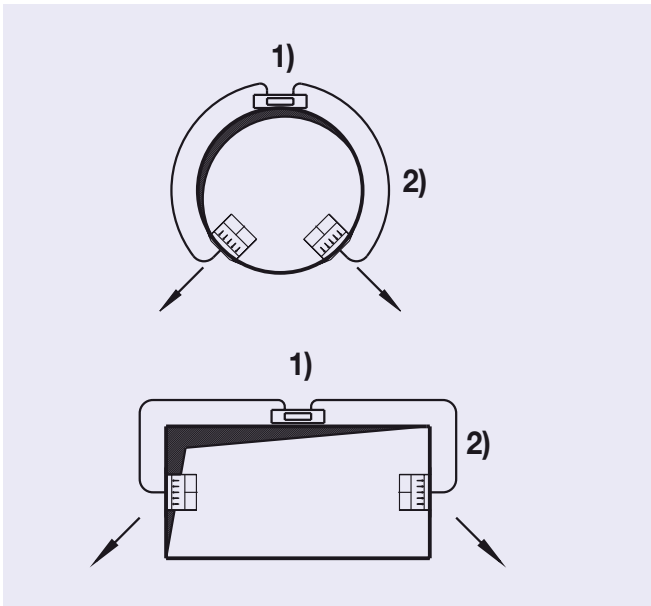

### 5.2.1 Installations 24 V

Installation directly on the duct can most easily be carried out with a 5-core flat ribbon cable (e.g. from Woertz, Basle).

This system consists of a 5-core cable, junction boxes for connecting the DGVAR motors, and clamps, connection boxes and terminals.

### 5.2.2 Transformer (supplied by user)

Secondary voltage: 24 VAC~, 50 Hz  
Power: To calculate transformer power  $S_T$ , the number of drives should be multiplied by 4 VA.

$$S_T = \text{number DGVAR} \times 4 \text{ VA}$$

Where  $S_T$  = transformer power in VA  
The value obtained is usually rounded to the next higher off-the-shelf value.

### 5.2.3 Supply wiring

For supply wiring (from the control unit to the flat cable) a minimum of 1.5 mm<sup>2</sup> wire should be used. For long supplies, and for cases where a large number of motors are fed by the same supply wiring, the voltage drop in this wiring should be taken into account. Care should be taken that each motor receives 24 V ~ ±20% between terminals 1 and 2.

To calculate the voltage drop in the wiring a consumption of 2 VA per DGVAR has to be assumed.

A maximum of 2 wires per terminal can be connected to the STG2VAR control unit. In the case of several supply wires a junction box should be mounted before the STG2VAR control unit.

### Important indication

If the installation is switched on and off on the secondary side (24VAC ~, 50 Hz), then 2-poles switches should be used in the supply wiring.

## 5.3 Installation of the electro technical devices

### 5.3.1 STG2VAR control unit

#### a) Installation in the control cabinet

The rear part of the control unit can be put on the standardized rails to be found in control cabinets. The front part (control unit) is subsequently fastened to the rear part by means of 4 screws.

### 5.3.2 KTF2VAR duct temperature sensor

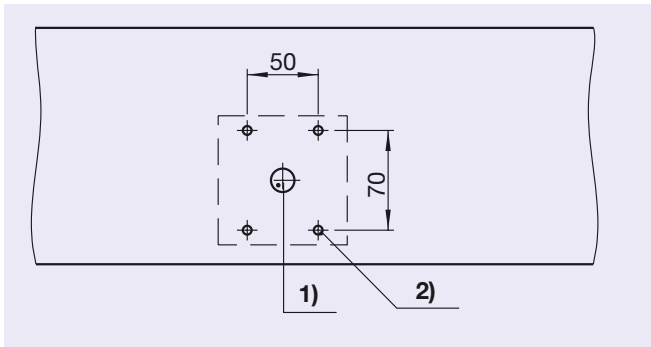

- 1) Centre hole  $\varnothing 14$
- 2) Fixing hole ( $\varnothing$  to suit method of fixing)

The duct temperature sensor is screwed directly to the duct.

### 5.3.3 SGA2VAR position indicator

#### a) Mounting on rendering

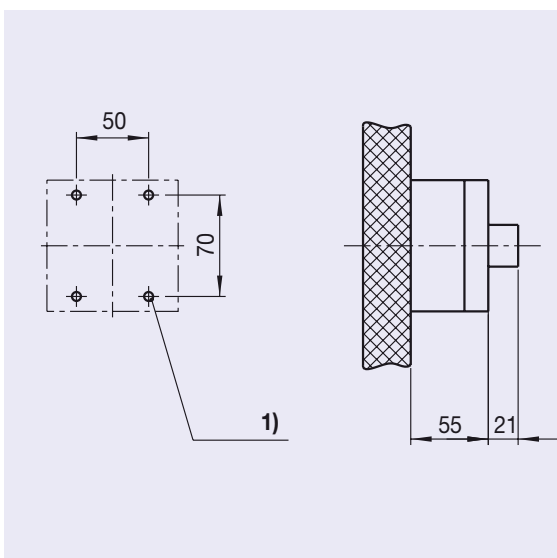

- 1) Fixing hole ( $\varnothing$  to suit method of fixing)

#### b) Installation in wall of control cabinet

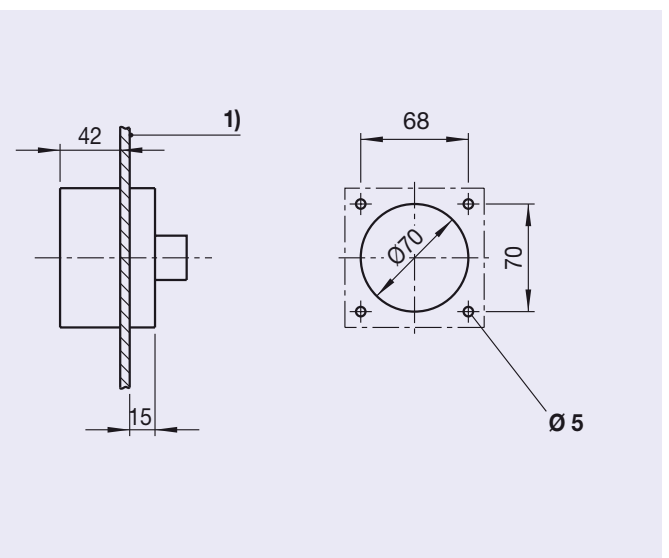

- 1) Wall of cabinet, max 2 mm

## 5.4 Start-up

### 5.4.1 Blade positions as given by the control unit STG2VAR position indicator

(Settings applies also to position indicator SGA2VAR)

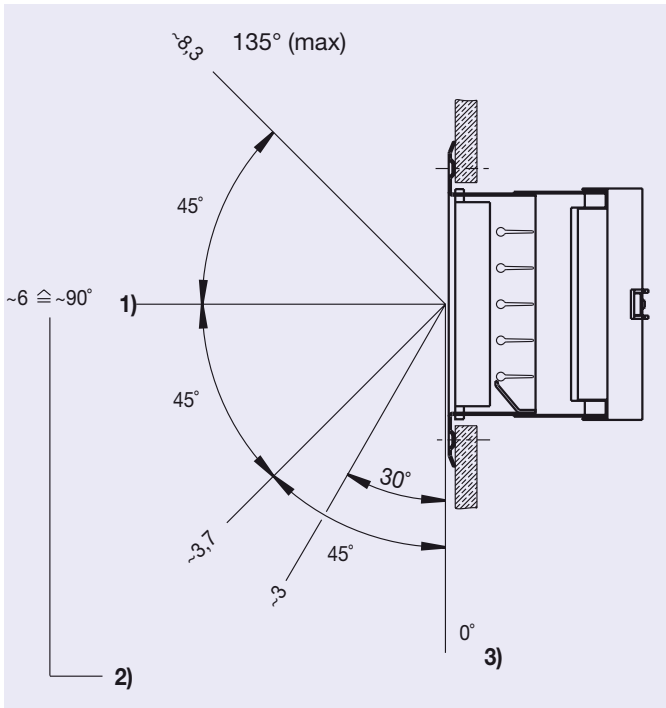

- 1) straight (corresponds to "black point by 6 VDC", fig. 33)
- 2) Setting of potentiometers W1 to W5
- 3) Setting CLOSED

### 5.4.2 Temperature-controlled installation with STG2VAR control unit and KTF2VAR duct temperature sensor

On start-up the procedure is as follows:

- Check installation and wiring.
- Switch on mains and check that the 24 volt supply is present (ventilator must be switched off).
- Set control unit change-over switch to 'MANO'. The green LED of setting control W5 should light.
- Turn setting control W5 to check that all outlets are working and that they open and close in parallel.
- Set the two temperature setting controls T1 and T2 as far to the right as possible (50°C).
- Set the change-over switch to 'AUTO'. The green LED of setting control W1 should light.
- Use setting control W1 to set the blades for cooling mode (at figure 7.5, more precise setting comes later).
- Set temperature setting control T1 as far as possible to the left (0°C). The green LED of setting control W2 should light.
- Use setting control W2 to set the blades for ventilation (isotherm), (at figure 6, more precise setting comes later).
- Set temperature setting control T2 as far as possible to the left (0°C). The green LED of setting control W3 should light.
- Use setting control W3 to set the blades for heating mode, at figure 4.5, more precise setting comes later.
- Use setting control W4 to set the blades for rapid warm-up (at figure 4, more precise setting comes later).
- Set the required temperature threshold values T1 and T2 (p.e. 18 °C and 25 °C).
- Switch on ventilator.

The precise adjustment of W1, W2 and W3 follows and depends on the supply temperature, the location of the DGVAR and the characteristics of the building. It can only take place after the installation has been running for some time (smoke tests).

If additional functions are incorporated in the installation, the following points should be taken into consideration:

**a) Rapid warm-up**

- Simulate change-over by time switch: the red LED of setting control W4 should light. All selected outlets which have not to blow, move to the closed position, the other outlets move to the position set by setting control W4.
- Set the required time for the time-switch.

**b) 2-stage installations**

- Simulate reduced intake. The red LED by the ventilator sign should light. All selected outlets which have not to blow, move to the closed position, the other outlets move to the position set by the currently active setting control W1, W2 or W3.

**c) Adder-subtractor PAS2VAR**

- When the knob is set to 0 = no change to blowing setting.
- A change of **one** segment in the position of the knob (+ or -) = 30° changing in the blowing setting.

**5.4.3 Manual control of the DGVAR supply air outlets using the SGA2VAR position indicator**  
(Settings applies also to the control unit STG2VAR)

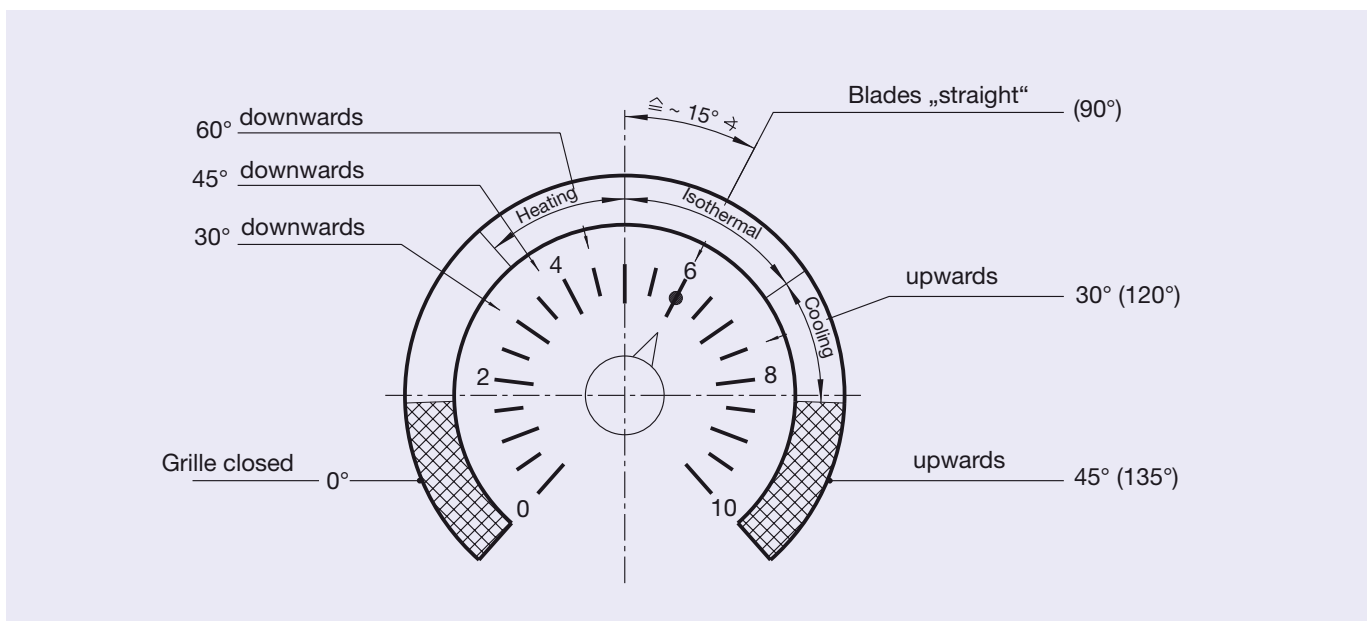

On start-up the procedure is as follows:

- Check installation and wiring.
- Switch on main supply and check that the 24-volt supply is present.
- Turn the knob on the position indicator and check that all outlets are working, and that they open and close in parallel.
- The air outlets can be adjusted by using the knob on the position indicator SGA2VAR to suit on the temperature of the conditioning air and the position in which they are installed. They should be adjusted to blow downwards in heating mode and upwards in cooling mode. For simple ventilation they should be set to blow between the setting for heating and cooling modes. (Isotherm)
- Switch on the ventilator.

**Recommendation:**

The DGVAR should not be closed when the ventilator is running, as this could lead to distension of the duct. If these instructions are not complied with, we shall not be responsible for the cost of repair of any resulting damage.

## 6. Summary and important notes concerning the DGVAR system (planning notes)

### 6.1. To ensure the functioning of the DGVAR system, the following instructions must be observed.

**6.1.1** At least a **4-core** connection cable must be used (from the control unit as far as the DGVAR connector box), see pages 4 + 5 in Fig. 6. Our recommendation is that of **always** using the 5-core flat ribbon cable supplied by Wörtz in Basel.

**6.1.2** The drive is **always** factory-fitted (air outlet and drive are works tested).  
Characteristics:  
3-core drive cables, approximately 1.3 m long  
24 VAC supply voltage, 50/60 Hz  
0 ... 10 VDC control voltage  
at 6 VDC, the direction of blow is identical with that of the incorporation of the grille;  
for further information, see page 14, point 4.1

**6.1.3** „Heating up” function.  
Important: Connect DGVAR grilles in the same air channel alternately to Y1 (contact 11) and Y2 (contact 12).  
The grilles connected to Y2 (12) travel to (0 VDC).  
The grilles connected to Y1 (11) blow downwards at an almost double speed of blow; see pages 4 + 5.  
The grilles connected to Y1 (11) cannot be made to travel to the CLOSED position, since the STG2VAR (control unit) always gives 3 VDC, whereby duct distension is prevented.

**6.1.4** For the calculation of the transformer performance (drive supply), it is necessary to supply 4 VA per grille; see page 22, point 5.2.2.

### 6.2 Application of the DGVAR as an OPEN/CLOSE function (no DGVAR system operation is possible, without the STG2VAR control unit).

**6.2.1** For the above mentioned type of OPEN/CLOSE operation, the DGVAR grilles must clearly be specified as type DGVAR ...AZ

**6.2.2** The wiring must be at least 3-core; see page 13, point 3.2.

**6.2.3** Switching contacts for OPEN/CLOSE are to be installed by the customer.

**Attention:** Depending on the type of application, the static pressure in the duct is to be controlled by means of pressure transmitters and the fan output is to be reduced. If these instructions are not complied with, we shall not be responsible for the cost of repair of the resulting damage (e.g. duct distension).

These points must be observed in all circumstances, because only thus can perfect functioning be secured.