



CAV CONTROLLERS TYPE
RN-EX



TESTED TO VDI 6022



ATEX-ZERTIFIZIERUNG

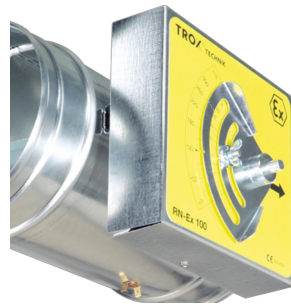

ADJUSTMENT SCALE

RN-EX

FOR THE PRECISE CONTROL OF CONSTANT VOLUME FLOWS IN POTENTIALLY EXPLOSIVE ATMOSPHERES (ATEX)

Circular, mechanical self-powered volume flow controllers for the control of supply air or extract air in constant air volume systems, approved and certified for potentially explosive atmospheres (ATEX)

- ATEX-compliant construction
- Approved for gases, mists, vapours and dusts in zones 1, 2, 21 and 22
- Volume flow rate can be set using an external scale, no tools required
- No on-site test measurements required for commissioning
- Suitable for airflow velocities of up to 12 m/s
- Any installation orientation
- Casing air leakage to EN 1751, class C

Optional equipment and accessories

- Acoustic cladding for the reduction of case-radiated noise
- Secondary silencer Type CA for the reduction of air-regenerated noise

Application



Application

- Circular EXCONTROL CAV controllers of Type RN-Ex for the precise supply air or extract air flow control in constant air volume systems
- For use in potentially explosive atmospheres (ATEX)
- Mechanical self-powered volume flow control without external power supply
- Simplified project handling with orders based on nominal size

Special features

- ATEX mark and certification
- ATEX equipment group II, approved for zones 1, 2, 21 and 22
- Volume flow rate can be set using an external scale; no tools required
- High volume flow rate control accuracy
- Any installation orientation
- Correct operation even under unfavourable upstream or downstream conditions (1.5 D straight section required upstream)

Classification

According to type examination certificate TUEV 05 ATEX 7159 X

- Zones 1 and 2 (atmosphere: gases): II 2 G c II T5 / T6
- Zones 21 and 22 (atmosphere: dusts): II 2 D c II T 80 °C

Nominal sizes

- 80, 100, 125, 160, 200, 250, 315, 400

Variants

- RN-Ex: Volume flow controller
- RN-Ex-D: Volume flow controller with acoustic cladding Units with acoustic cladding and/or Type CA secondary silencers for demanding acoustic requirements
- Acoustic cladding cannot be retrofitted

Construction

- Galvanised sheet steel
- P1: Powder-coated, silver grey (RAL 7001)
- A2: Stainless steel

Parts and characteristics

- Ready-to-commission controller
- Damper blade with low-friction bearings
- Bellows that acts as an oscillation damper
- Cam plate with leaf spring
- Scale with pointer to set the volume flow rate setpoint
- Connection for equipotential bonding
- Aerodynamic function testing of each unit on a special test rig prior to shipping

Accessories

- Lip seals on both ends (factory fitted)

Useful additions

- Circular silencers CA (for Germany and Switzerland) and CAH (for EMEA)
- Pipe silencer to be ordered separately

Construction features

- Circular casing
- Construction and materials comply with the EU directive for use in potentially explosive atmospheres (ATEX)
- Spigot suitable for circular ducts to EN 1506 or EN 13180
- Spigot with insert bead for lip seal; (except RN-Ex-P1/80 not possible with insert bead/lip seal)

Materials and surfaces

Galvanised sheet steel construction

- Casing made of galvanised sheet steel
- Interior parts, nominal sizes 80 - 125: stainless steel 1.4301, nominal sizes 160 - 400: galvanised sheet steel
- Polyurethane bellows
- Plain bearings with PTFE coating
- Leaf spring made of stainless steel

Powder-coated (P1)

- Casing made of galvanised sheet steel, powder-coated
- Interior parts, nominal sizes 80 - 125: stainless steel 1.4301, nominal sizes 160 - 400: galvanised sheet steel, powdercoated

Stainless steel construction (A2)

- Casing made of stainless steel 1.4301
- Interior parts made of stainless steel

Variant with acoustic cladding (-D)

- Acoustic cladding made of galvanised sheet steel
- Rubber seal for the insulation of structure-borne noise
- Lining made of mineral wool

Mineral wool

- Acc. to EN 13501, fire rating class A1, non-combustible
- RAL quality mark RAL-GZ 388
- Harmless to health due to high biosolubility, according to TRGS 905 as well as EU Directive 97/69/EC

Standards and guidelines

- Directive 94/9/EC: Equipment and protective systems intended for use in potentially explosive atmospheres
- Meets the hygiene requirements of VDI 6022
- Casing air leakage acc. to EN 1751, class C

Maintenance

- Maintenance-free, as construction and materials are not subject to wear and tear

TECHNICAL INFORMATION

Functional description

The volume flow controller is a mechanical self-powered unit and works without external power supply. A damper blade with low-friction bearings is adjusted by aerodynamic forces such that the set volume flow rate is maintained within the differential pressure range.

The aerodynamic forces of the airflow create a closing torque on the damper blade. The bellows extends and increases this force while at the same time acting as an oscillation damper. The closing force is countered by a leaf spring that unrolls over a cam plate. The shape of the cam plate is such that a change in the differential pressure leads to an adjustment of the damper blade in a way that the volume flow rate is maintained almost exactly.

Efficient commissioning

The volume flow rate setpoint value can be set quickly and easily using the pointer on the external scale; no measurements are required.

The advantage over flow adjustment dampers is that there is no need for repeat measurements or adjustments by an air conditioning engineer. Should the system pressure change, e.g. by opening or closing of duct sections, the flow rates in the entire system will also change if flow adjustment dampers are used; however, this is not the case with mechanical self-powered volume flow controllers. A mechanical self-powered controller reacts immediately and adjusts the damper blade such that the set constant volume flow rate is maintained.

Schematic illustration of the RN-Ex

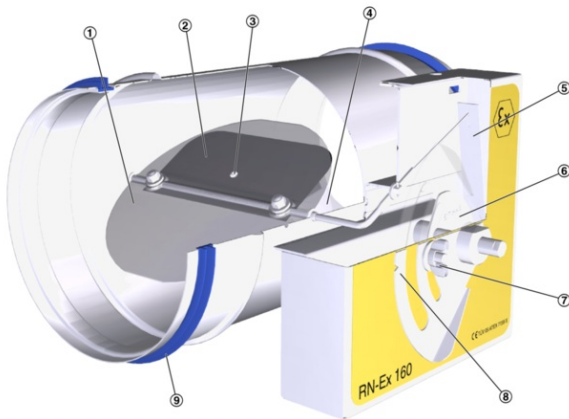

- ① Damper blade
- ② Bellows
- ③ Bellows inlet
- ④ Crossbar
- ⑤ Leaf spring
- ⑥ Cam plate
- ⑦ Volume flow rate scale lock
- ⑧ Volume flow rate scale
- ⑨ Lip seal

Volume flow rate ranges

The minimum differential pressure of CAV controllers is an important factor in designing the ductwork and in rating the fan including speed control.

Sufficient duct pressure must be ensured for all operating conditions and for all control units. The measurement points for fan speed control must be selected accordingly.

Nominal sizes	80 – 400 mm
Volume flow rate range	11 – 1400 l/s or 40 – 5040 m ³ /h
Volume flow rate control range	Approx. 25 to 100 % of the nominal volume flow rate
Scale accuracy	± 4 %
Minimum differential pressure	50 Pa (nominal size 80: 100 Pa)
Maximum differential pressure	1000 Pa
Operating temperature	10 – 50 °C

Circular volume flow controllers for constant air volume systems in potentially explosive atmospheres, mechanical self-powered, without external power supply, suitable for supply or extract air, available in 8 nominal sizes.

Ready-to-commission unit consists of the casing containing a damper blade with low-friction bearings, bellows, external cam plate with leaf spring, and parts for equipotential bonding and for protection in potentially explosive atmospheres.

Volume flow controllers are factory set to a reference volume flow rate (customers can set the required volume flow rate on site).

Spigot with groove for lip seal, suitable for connecting ducts according to EN 1506 or EN 13180.

Casing air leakage to EN 1751, class C.

Special features

- ATEX mark and certification
- ATEX equipment group II, approved for zones 1, 2, 21 and 22
- Volume flow rate can be set using an external scale; no tools required
- High volume flow rate control accuracy
- Any installation orientation
- Correct operation even under unfavourable upstream or downstream conditions (1.5 D straight section required upstream)

Materials and surfaces

Galvanised sheet steel construction

- Casing made of galvanised sheet steel
- Interior parts, nominal sizes 80 – 125: stainless steel 1.4301, nominal sizes 160 – 400: galvanised sheet steel
- Polyurethane bellows
- Plain bearings with PTFE coating
- Leaf spring made of stainless steel

Powder-coated construction (P1)

- Casing made of galvanised sheet steel, powder-coated
- Interior parts, nominal sizes 80 – 125: stainless steel 1.4301, nominal sizes 160 – 400: galvanised sheet steel, powder-coated

Stainless steel construction (A2)

- Casing made of stainless steel 1.4301
- Interior parts made of stainless steel

Variant with acoustic cladding (-D)

- Acoustic cladding made of galvanised sheet steel
- Rubber profile for the insulation of structure-borne noise
- Lining is mineral wool

Mineral wool

- To EN 13501, fire rating class A1, non-combustible
- RAL quality mark RAL-GZ 388
- Biosoluble and hence hygienically safe according to the German TRGS 905 (Technical Rules for Hazardous Substances) and EU directive 97/69/EC

Construction

- Galvanised sheet steel
- P1: Powder-coated, silver grey (RAL 7001)
- A2: Stainless steel

Technical data

- Nominal sizes: 80 to 400 mm
- Volume flow rate range: 11 to 1400 l/s or 40 to 5040 m³/h
- Volume flow rate control range: approx. 25 - 100 % of the nominal volume flow rate
- Minimum differential pressure: 50 Pa (nominal size 80: 100 Pa)
- Maximum differential pressure: 1000 Pa

Sizing data

- V _____ [m³/h]
- Δp_{st} _____ [Pa]

Air-regenerated noise

- L_{PA} _____ [dB(A)]

Case-radiated noise

- L_{PA} _____ [dB(A)]

This specification text describes the general properties of the product. Texts for variants can be generated with our Easy Product Finder design programme.

1 Type

RN-Ex Volume flow controller for potentially explosive atmospheres

2 Acoustic cladding

No entry: none

D with acoustic cladding

3 Material

No entry: galvanised sheet steel

P1 Powder-coated RAL 7001 (silver grey)

A2 Stainless steel construction

4 Nominal size [mm]

80, 100, 125, 160, 200, 250, 315, 400

5 Accessories

No entry: without accessories

D2 Double lip seal both ends

Order example: RN-Ex/160/D2

Nominal size	160
Material	Galvanised sheet steel
Accessories	Lip seals on both ends

RN-Ex-D-P1/160/D2

1 2 3 4 5