



HEAT EXCHANGER
TYPE EL



ELECTRIC AIR HEATER
WITH PLAIN STAINLESS
STEEL HEATING COIL

Electric air heater with plain
stainless steel heating coil

EL-UK

FOR THE ELECTRIC REHEATING OF AIRFLOWS IN CIRCULAR DUCTING

Circular electric air heater for reheating airflows, suitable for VAV terminal units TVR and mechanical self-powered CAV controllers RN and VFC

- Outlet airflow temperature 50 °C max.
- Plain heating coil, stainless steel 1.4301
- Integral overheating protection with temperature monitor (auto reset) and thermal cut-out (manual reset)
- For horizontal or vertical ducts
- Suitable for circular ducts to EN 1506 or EN 13180
- With lip seal
- Protection level: IP 43
- Casing leakage according to EN 15727, class C

General information

Application

- Electric air heater for reheating airflows up to 50 °C in circular ducts
- For VAV terminal units Type TVR and for CAV controllers Type RN or VFC

Nominal sizes

- 100, 125, 160, 200, 250, 315, 400



Parts and characteristics

- Ready-to-install air heater
- Twofold overheating protection:
 - Temperature monitor with automatic reset
 - Thermal cut-out with manual reset
- Connection terminals inside
- Casing is ready for cable feedthrough; strain relief and cable gland (M20 or M25) to be provided by others

Construction features

- Circular casing with rectangular switch cabinet
- Spigot with lip seal, for circular connecting ducts to EN 1506 or EN 13180
- The heating coil is an encased plain pipe
- IP 43

Materials and surfaces

- Casing and switch cabinet made of galvanised sheet steel
- Heating coil made of stainless steel 1.4301

Standards and guidelines

- Casing air leakage to EN 15727, class C

Maintenance

- Regular functional tests, especially of the thermal cut-out

Useful additions

- Capacity control is required (to be provided by others)
- Airflow monitoring is required (to be provided by others)

TECHNICAL INFORMATION

Technical data, Quik sizing, Specification text, Order code



Nominal sizes	100 - 400 mm
Volume flow rate range	12 - 750 l/s or 43 - 2700 m ³ /h
Electrical power consumption	0,4 - 9 kW
Minimum airflow velocity	1.5 m/s (airflow monitoring required, by others)
Maximum outlet airflow temperature	50 °C (capacity control required, by others)
Maximum operating temperature	Without integral control = 40 °C max.
Release temperature - temperature monitor TW	Approx. 60 °C (automatic reset if the value falls below this temperature; hysteresis approx. 15 K)
Release temperature for thermal cut-out	Approx. 90 °C (manual reset on the air heater required)
Air-side static differential pressure	5 - 75 Pa
Supply voltage NS 100	230 V AC, 400 W
Supply voltage NS 125	230 V AC, 900 W
Supply voltage NS 160	230 V AC, 1200 W
Supply voltage NS 200	230 V AC, 2100 W
Supply voltage NS 250	400 V AC 2-phase, 3000 W
Supply voltage NS 315	400 V AC 3-phase, 6000 W
Supply voltage NS 400	400 V AC 3-phase, 9000 W
Protection level	IP 43
EC conformity	EMC to 2014/30/EU, low voltage to 2014/35/EU
Licence	CE, UKCA, S, EAC

Technical data - electric air heater

Basic units: TVR, RN and VFC

NS	q _v		Δp _{st} [Pa]	t _e = 16 °C	
	l/s	m ³ /h		P [kW]	t _a [°C]
100	12	43	5	0.4	44
100	20	72	10	0.4	33
100	30	108	15	0.4	27
100	40	144	25	0.4	24
100	45	162	30	0.4	23
125	24	85	5	0.9	48
125	35	126	20	0.9	37
125	50	180	40	0.9	31
125	65	234	60	0.9	27
125	75	270	80	0.9	26
160	30	108	5	1.2	49
160	50	180	10	1.2	36
160	70	252	15	1.2	30
160	95	342	25	1.2	26
160	115	414	35	1.2	25
200	59	210	5	2.1	46
200	80	288	20	2.1	38
200	115	414	35	2.1	31
200	150	540	55	2.1	28
200	180	648	80	2.1	26
250	77	275	5	3	49
250	125	450	15	3	36
250	180	648	25	3	30
250	235	846	40	3	27
250	290	1044	60	3	25
315	153	550	5	6	49
315	200	720	15	6	41
315	285	1026	25	6	33
315	375	1350	40	6	29
315	460	1656	60	6	27
400	228	820	5	9	49
400	325	1170	15	9	39
400	465	1674	30	9	32
400	605	2178	50	9	28
400	750	2700	75	9	26

P: Electrical power consumption
t_e: Inlet airflow temperature
t_a: Outlet airflow temperature
q_v: Volume flow rate
Δp_{st}: Static differential pressure

Specification text

Electric air heater for reheating airflows in ventilation and air conditioning systems. Dimensions fit VAV terminal units TVR as well as CAV controllers RN and VFC. Integral twofold overheating protection with temperature monitor and thermal cut-out. Spigot with lip seal for ducts according to EN 1506 or EN 13180. Casing leakage according to EN 15727, class C.

Materials and surfaces

- Casing and switch cabinet made of galvanised sheet steel
- Heating coil made of stainless steel 1.4301

Technical data

- Volume flow rate range: 12 to 750 l/s or 43 to 2700 m³/h
- Electrical power consumption: 0.4 to 9 kW
- Maximum outlet airflow temperature: 50 °C
- Static differential pressure: 5 to 80 Pa
- Supply voltage: 1 × 230 V AC to 3 × 400 V AC
- Protection level: IP 43

Sizing data

- q_v [m³/h]
- P [kW]

EL
|
1

/

160
|
2

1 Type

EL Electric air heater for VAV terminal units TVR and for CAV controllers RN and VFC

2 Nominal size [mm]

100, 125, 160, 200, 250, 315, 400

Order Example: EL/160

Nominal size 160 mm

Dimensions and weights of the electric air heater

NS	ØD	H ₃	m [kg]
100	99	116	2
125	124	141	2.5
160	159	176	2.9
200	199	216	3.7
250	249	266	4.5
315	314	331	6.7
400	399	416	8.1

Electric air heater - dimensions

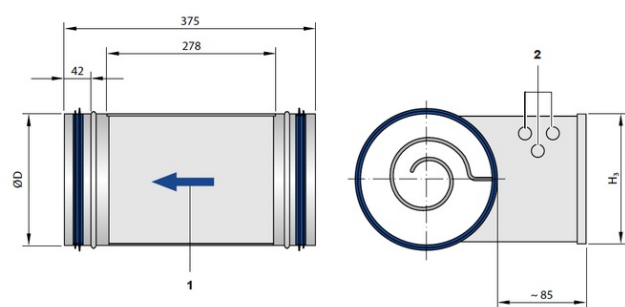

1 Arrow indicating the airflow direction (on the side of the control equipment box)

2 Cable penetrations

General information on commissioning

- Installation in horizontal or vertical ducts
- Installation only in ducts made of non-cumbersome and temperature resistant material
- An arrow at the side of the casing indicates the only acceptable airflow direction
- A straight duct section of at least 2D is required upstream and downstream of:
 - components such as volume flow controllers, flow adjustment dampers, valves and filters
 - bends, junctions or a narrowing or widening of the duct
- We recommend installing the air heater downstream of a VAV terminal unit, otherwise the terminal unit's flow rate measuring system may be affected by the higher air temperature
- The control equipment box may be fitted on the top or at the side (90° max.). The control equipment box must not be fitted at the bottom of the duct
- At least 30 mm distance between the sheet metal casing and wood or other combustible materials
- Capacity control and supply connections to be provided by others
- Airflow monitoring is required and to be provided by others

Correct assignment of types for installation, wiring and commissioning; see also the manufacturer's documentation

Order code	Type according to manufacturer (see installation manual)
EL/100	CV10 - 04 - 1M
EL/125	CV12 - 09 - 1M
EL/160	CV16 - 12 - 1M
EL/200	CV20 - 21 - 1M
EL/250	CV25 - 30 - 2M
EL/315	CV31 - 60 - 3M
EL/400	CV40 - 90 - 3M

Space required

NS	①	②	③
100	320	125	300
125	320	150	300
160	320	185	300
200	320	225	300
250	320	275	300
315	320	340	300
400	320	425	300

Access to control equipment box and reset device for the thermal cut-out

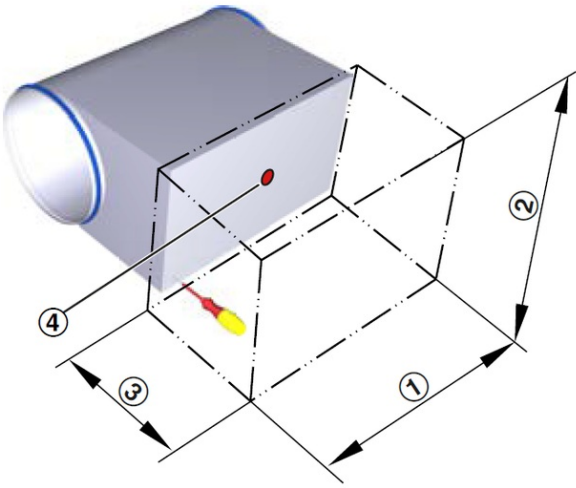

④ Reset button