



FV-EU



TESTED TO VDI 6022



WITH TROXNETCOM AS
AN OPTION



CE COMPLIANT
ACCORDING TO
EUROPEAN
REGULATIONS

FV-EU

FIRE PROTECTION VALVES FOR SUPPLY AND EXTRACT AIR

Circular fire protection valve for the isolation of duct penetrations between fire compartments; suitable for supply air and extract air systems. They also satisfy ventilation requirements

- Nominal sizes Ø 100, 125, 160, 200 mm

- For installation in walls and ceilings
- Low differential pressure and sound power level
- Integration into the central BMS with TROXNETCOM

Optional equipment and accessories

- Electric limit switch
- Extension piece
- Trim ring, circular or square

General Information



Application

- Fire protection valves of Type FV-EU, with CE marking and declaration of performance, for the isolation of duct penetrations between fire compartments in the event of a fire
- To prevent the propagation of fire and smoke through ductwork to adjacent designated fire compartments

Special characteristics

- Declaration of performance according to Construction Products Regulation
- Classification to EN 13501-3, up to EI 120 ($v_e, h_o, i \leftrightarrow o$) S
- Building inspectorate licence Z-56.4212-991 for fire resistance properties
- Complies with the requirements of EN 15650
- Tested to EN 1366-2 for fire resistance properties
- Hygiene complies with VDI 6022 part 1 (07/2011), VDI 3803 (10/2002), DIN 1946 part 4 (12/2008), and EN 13779 (09/2007)
- Corrosion protection according to EN 15650 in connection with EN 60068-2-52
- Closed valve cone air leakage to EN 1751, class 2
- Low differential pressure and sound power level
- Any airflow direction

Classification

- Class of performance to EN 13501-3, up to EI 120 ($v_e, h_o, i \leftrightarrow o$) S

Nominal sizes

- Ø100, 125, 160, 200 mm
- L: 150 mm

Variants

- With fusible link
- With fusible link and limit switch

Attachments

- Limit switch for capturing the valve position
- Network module for the integration with AS-i networks

Accessories

Mortar-based installation

- Trim ring, circular
- Trim ring, square
- Flexible connectors
- Extension piece

Construction features

- Adjustment device for large or small air volumes
- Valve cone with bayonet fixing
- Integration into the central BMS with TROXNETCOM

Materials and surfaces

- Installation subframe, spigot and valve disc made of sheet steel
- Installation subframe and spigot with stove-enamelled finish, black

- Exposed surface of valve disc powder-coated RAL 9010
- Valve cone made of special insulation material
- Seal made of polyurethane
- Attachments made of galvanised steel
- Increased corrosion protection due to powder-coated casing

Standards and guidelines

- Construction Products Regulation
- EN 15650:2010 Ventilation for buildings – fire dampers
- EN 1366-2-1999 Fire resistance tests for service installations – Fire dampers
- EN 13501-3:2010 Fire classification of construction products and building elements
- EN 1751:1999 Ventilation for buildings – Air terminal devices

Maintenance

- The functional reliability of the fire protection valve must be tested at least every six months; this has to be arranged by the owner of the ventilation system; functional tests must be carried out in compliance with the basic maintenance principles stated in EN 13306 and DIN 31051. If two consecutive tests, one 6 months after the other, are successful, the next test can be conducted one year later.
- Fire protection valves must be included in the regular cleaning schedule of the ventilation system
- For details on maintenance and inspection refer to the installation and operating manual
-



TECHNICAL INFORMATION

Functional description

In the event of a fire, fire protection valves shut automatically to prevent the propagation of fire and smoke through ductwork to adjacent designated fire compartments.

In the event of a fire, the valve is triggered at 72 °C by a fusible link. The release mechanism is accessible and can be tested from the outside.

Schematic illustration of the FV-EU with extension piece and limit switches

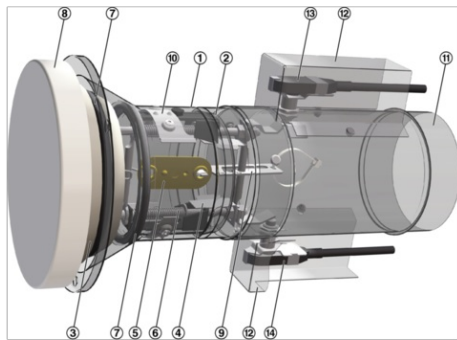

- ① Installation subframe (subframe and fixing material are supplied separately)
- ② Spigot
- ③ Valve cone
- ④ Flat springs
- ⑤ Fusible link 72 °C
- ⑥ Spring (for closure)
- ⑦ Seal
- ⑧ Valve disc with seal
- ⑨ Adjustment device (position 1: large air volume; position 2: small air volume)
- ⑩ Bayonet fixing
- Extension piece
- Sheet metal cover
- Limit switch, indicating OPEN
- Limit switch, indicating CLOSED

| | |
|-------------------------------|---|
| Nominal sizes | Ø100, 125, 160, 200 mm |
| Casing length | 150 mm (300 mm with extension piece) |
| Release temperature | 72 °C |
| Operating temperature | 0 to 50 °C |
| Volume flow rate range | Extract air up to 400 m³/h or supply air up to 210 m³/h |

Volume flow rate at differential pressure $\Delta p_{st} < 35$ Pa (supply air)

| L _{WA} [dB(A)] | 25 | | 35 | | 45 | | 25 | | 35 | | 45 | |
|-------------------------|-----|----|-----|----|-----|----|-------------------|----|-------------------|----|-------------------|----|
| Nominal size | V | | | | | | | | | | | |
| mm | l/s | Pa | l/s | Pa | l/s | Pa | m ³ /h | Pa | m ³ /h | Pa | m ³ /h | Pa |
| 100 | 15 | 22 | 21 | 42 | 29 | 82 | 55 | 22 | 75 | 42 | 105 | 82 |
| 125 | 20 | 19 | 29 | 39 | 40 | 72 | 73 | 19 | 105 | 39 | 143 | 72 |
| 160 | 19 | 13 | 28 | 28 | 39 | 57 | 68 | 13 | 100 | 28 | 142 | 57 |
| 200 | 24 | 14 | 33 | 28 | 49 | 60 | 85 | 14 | 120 | 28 | 175 | 60 |

Volume flow rate at differential pressure $\Delta p_{st} < 35$ Pa (extract air)

| L _{WA} [dB(A)] | 25 | | 35 | | 45 | | 25 | | 35 | | 45 | |
|-------------------------|-----|----|-----|----|-----|----|-------------------|----|-------------------|----|-------------------|----|
| Nominal size | V | | | | | | | | | | | |
| mm | l/s | Pa | l/s | Pa | l/s | Pa | m ³ /h | Pa | m ³ /h | Pa | m ³ /h | Pa |
| 100 | 17 | 18 | 25 | 38 | 35 | 75 | 62 | 18 | 90 | 38 | 126 | 75 |
| 125 | 13 | 5 | 27 | 21 | 58 | 99 | 48 | 5 | 97 | 21 | 210 | 99 |
| 160 | 21 | 11 | 36 | 32 | 58 | 83 | 75 | 11 | 130 | 32 | 210 | 83 |
| 200 | 24 | 10 | 39 | 27 | 67 | 81 | 85 | 10 | 140 | 27 | 240 | 81 |

Fire protection valve for the isolation of duct penetrations between fire compartments. For use in supply air and extract air systems; with two-stage adjustment device for adjusting the air volume.

Ready-for-operation unit, which includes a fire-resistant valve cone and a release mechanism.

Tested for fire resistance properties to EN 1366-2, with CE marking and declaration of performance according to the Construction Products Regulation.

For mortar-based installation into solid walls and ceiling slabs, and into lightweight partition walls with metal support structure and cladding on both sides.

Casing length 150 mm (300 mm with extension piece)

For the connection to ducts made of non-combustible or combustible materials.

Thermal release at 72 °C.

Special characteristics

- Declaration of performance according to Construction Products Regulation
- Classification to EN 13501-3, up to EI 120 ($v_e, h_o, i \leftrightarrow o$) S
- Building inspectorate licence Z-56.4212-991 for fire resistance properties
- Complies with the requirements of EN 15650
- Tested to EN 1366-2 for fire resistance properties
- Hygiene complies with VDI 6022 part 1 (07/2011), VDI 3803 (10/2002), DIN 1946 part 4 (12/2008), and EN 13779 (09/2007)
- Corrosion protection according to EN 15650 in connection with EN 60068-2-52
- Closed valve cone air leakage to EN 1751, class 2
- Low differential pressure and sound power level
- Any airflow direction

Materials and surfaces

- Installation subframe, spigot and valve disc made of sheet steel
- Installation subframe and spigot with stove-enamelled finish, black
- Exposed surface of valve disc powder-coated RAL 9010
- Valve cone made of special insulation material
- Seal made of polyurethane
- Attachments made of galvanised steel
- Increased corrosion protection due to powder-coated casing

Technical data

- Nominal sizes: Ø100, 125, 160, 200 mm
- Casing length 150 mm (300 mm with extension piece)
- Release temperature: 72 °C
- Operating temperature: 0 to 50 °C
- Volume flow rate range: Extract air up to 400 m³/h or supply air up to 210 m³/h

FV – EU / DE / 160 / R / Z05

1

2

3

4

5

1 Type

FV-EU Fire protection valve

2 Country of destination

DE Germany
Other destination countries upon request

3 Nominal size [mm]

100
125
160
200

4 Accessories

No entry: none
R Trim ring - circular
Q Trim ring - square

5 Attachments

Z04 - Z07